

Member Requirements for Electric Service and Upgrades



Phone: 724-349-4800 or 1-800-211-5667

E-mail: reaenergy@reaenergy.com

Fax: 724-349-7151

Effective January 25, 2011

REA *energy*
Cooperative Inc.



**Call the Experts at REA Energy Services
for all of Your Electrical and HVAC Needs.**

REA Energy Services Sells and Installs:

Heating and Air Conditioning

Electrical Contracting

Geothermal Heat Pumps

Back-Up Generators

Portable Generators

Tree Trimming and Removal

Water Heater Service Program

For more information, call **724-349-4800** or **1-800-211-5667**,
or **Visit us on the web at: www.reaenergy.com.**

Financing Available For Those Who Qualify

TABLE OF CONTENTS

	Page
1.0 Introduction.....	1
2.0 Definitions.....	2
3.0 Electric Services Available.....	3
4.0 General Requirements.....	3
4.01 Application for Electric Service.....	3
4.02 Extension of Cooperative's Facilities.....	3
4.03 Requirements for a Residential Structure to be Considered a Permanent Installation	3
4.04 Installation and Responsibility.....	4
4.05 Member Alterations and Additions.....	4
4.06 Requirements of Electrical Inspection.....	5
4.07 Swimming Pool Location.....	5
4.08 Buildings/Structures Near Electric Lines	5
4.09 Attachments on Cooperative-Owned Facilities.....	5
4.10 Requested Protection for Persons Working near Cooperative Facilities.....	5
4.11 Access to Member's Premises.....	5
4.12 Cooperative's Equipment on Member's Premises.....	6
4.13 Cooperative's Responsibility.....	6
4.14 Right to Refuse or Discontinue Service.....	6
4.15 Stand-by Generator Service.....	6
4.16 Transformer Foundations.....	6
5.0 Overhead Service Requirements (600 Volts or Less).....	7
5.01 General	7
5.02 Service Drop.....	7
5.03 Service Entrance	8
5.04 Connections Between Cooperative's & Member's Facilities	8
5.05 Permanent Overhead Service Installations.....	8
5.06 Temporary Overhead Service Installations.....	8
5.07 Mobile/Manufactured Home Overhead Service Installations.....	8
5.08 Recreation Vehicle Service Installations.....	9
5.09 Central Distribution Service Installations (Farm Pole).....	9
5.10 Small Non-Residential Service Installations.....	9
5.11 Overhead Services in Excess of 600 Volts.....	9
6.0 Underground Service Requirements (600 Volts or Less).....	9
6.01 General.....	9
6.02 Service Lateral (Residential).....	10
6.03 Service Lateral (Commercial or Industrial)	11

- 6.04 Service Entrance..... 11
- 6.05 Connections Between Cooperative's & Member's Facilities..... 12
- 6.06 Permanent Underground Service Installation..... 12
- 6.07 Temporary Underground Service Installation..... 12
- 6.08 Mobile/Manufactured Home Underground Service Installation..... 12
- 6.09 Underground Service Installations in Excess of 600 Volts..... 13
- 6.10 Excavation Near Utility Underground Facilities..... 13

7.0 Member Equipment..... 13

- 7.01 General..... 13
- 7.02 Motor Installations..... 13
- 7.03 Required Equipment Protections..... 14
- 7.04 Air Conditioners, Central Space heating, Heat Pumps Including Supplemental Heating Elements in Heat Pumps..... 15
- 7.05 Electric Water Heaters..... 15
- 7.06 Electric Welding, X-ray, Radio, Electronic Equipment, etc..... 15
- 7.07 Lightning and Surge Protection..... 15
- 7.08 Three-phase Converter..... 15

8.0 Meter Installations..... 16

- 8.01 General..... 16
- 8.02 Meter Locations. 16
- 8.03 Meter Relocations..... 17
- 8.04 Emergency Meter Removal..... 17
- 8.05 Group Meter Installation..... 17
- 8.06 Transformer-Rated Meter Installations..... 17
- 8.07 Transformer-Rated Metering at Pad-Mounted Transformer..... 17
- 8.08 Metering Communications..... 18
- 8.09 Seals..... 18

9.0 Meter Sockets..... 18

- 9.01 General..... 18
- 9.02 Member-Furnished Meter Sockets..... 19
- 9.03 Meter Socket Repairs/Replacements..... 19
- 9.04 Meter Socket Specifications..... 19

APPENDICES: SERVICE AND METER INSTALLATION SPECIFICATION

Overhead Service Installation 600 Volts or Less

Figure 1	Service Drop Clearance Minimums for Services Under 600 Volts.....	23
Figure 2	Typical Grounding Details.....	24
Figure 3	Typical 320 AMP or Less Overhead Service Installation.....	25
Figure 4	Temporary Overhead Service Support.....	26
Figure 5	Typical Overhead Service for Individually Located Mobile Homes.....	27
Figure 6	General Overhead Pole Mounted, Self – Contained – Pole Mounted Service Equipment.....	28
Figure 7a	Pole Mounted Self-Contained Meter Not Exceeding 320 AMPS, Member Central Distribution Service or Farm Meter Pole.....	29
Figure 7b	Pole Mounted Self Contained Meter Not Exceeding 320 AMPS, Member Central Distribution Service with Stand-by Generator Facilities or Farm Meter Pole.....	30
Figure 8	Stand-by Generator for 120/240 Volt Single-Phase Service (Member-owned).....	31
Figure 9	Typical Overhead Service Installation, Building Attachment, 3-Phase, 4-Wire Service.....	32
Figure 10	Connecting Multiple Services.....	33
Figure 11	Pole Mounted Transformer-Rated Metering (Cooperative-Owned Pole).....	34

Underground Service Installations 600 Volts or Less

Figure 20	Typical 320 AMP or Less Underground Service Installation.....	36
Figure 21	Typical Underground Mobile Home Service for Parks or Individually Located Homes.....	37
Figure 22	Temporary Underground Service Support at Transformer.....	38
Figure 23	Typical Transformer-Rated Metering Installation at Pad-Mounted Transformer (3-Phase, 4-Wire Service)	39
Figure 24	Clearance Requirements from Buildings for Pad-Mounted Transformer.....	40
Figure 25	Clearances of Pad-Mounted Equipment from Shrubs, Plants and Other Obstructions.....	41
Figure 26	Vehicular Barrier for Pad-Mounted Equipment.....	42
Figure 27	Concrete & Non-Concrete Pad Foundation Pad-Mounted Transformer General Notes.....	43
Figure 28	Typical Trenching Details for Installation of Secondary/Service Lateral and Primary Conduit.....	44
Figure 29	Typical Trenching Details for Installation of Secondary/Service Lateral and Primary Conduit General Notes.....	45

Meter Location and Installation

Figure 30	Residential Service-Meter Location.....	47
Figure 31	Self-Contained Meter Socket Connections.....	48
Figure 32	Multiple Meter Installation 240 Volts or Less.....	49

Figure 33 Pre-Assembled Multiple Meter Installation..... 50
Figure 34 Typical Transformer-Rated Metering Installation 600 Volts or Less – Outdoor Overhead..... 51

Fax Cover Sheet & Application Forms

Fax Cover
Sheet..... 53
New Residential Electrical Service..... 54
Upgrade Residential Service..... 55
New Non-Residential Electrical Service..... 56
Upgrade Non-Residential Service..... 57
Motor Specifications..... 58

1.0 INTRODUCTION

These “Member Requirements for Electric Service” are published as a reference for Members, Contractors, Architects, Engineers and other interested parties who may be concerned with installation considerations that the Cooperative’s experience has shown to be necessary in order to provide safe and satisfactory electric service.

It is the intention (not guarantee) of the Cooperative that the Member’s service facilities requirements in this booklet shall be consistent with all applicable federal, state, county and municipal regulations, laws, codes, and ordinances as may be in effect now or hereafter in the areas served by this Cooperative. To the extent such governmental regulations and codes are more stringent than the requirements herein, the regulations and codes shall control. To the extent such governmental regulations and codes are less stringent, the requirements herein shall control.

Requirements herein are not necessarily complete facility or safety specifications. Rather, it covers matters of mutual concern to the Member and the Cooperative, which facilitate the supplying of electric service. The requirements are subject to revision from time to time without notification so that they keep pace with developments and progress in the electric industry. Compliance with these requirements does not absolve the Member from obligation to install and maintain wiring and equipment in a safe condition; also, the Cooperative does not accept any responsibility for the quality or condition of the Member’s wiring and equipment. The Member shall comply with the latest edition of the National Electrical Code (NEC) and all applicable safety codes and practices.

Unless otherwise noted, statements and drawings in this booklet refer to services of 600 volts or less. Contact the Cooperative with questions regarding services at higher voltages and special residential, commercial and industrial requirements.

The Cooperative’s Rate Schedules and associated Rules and Regulations for all classes of service will be furnished to any Member upon request.

Mandatory rules of this document are those that identify actions that are specifically required or prohibited and are characterized by the use of terms **shall or shall not**.

Member grants the Cooperative such easements upon, over or under the Member’s lands for purposes of erecting, maintaining, repairing, and servicing all such pole lines, facilities and equipment as may be necessary or convenient in order to provide electric service to the Member. Member hereby agrees to execute, acknowledge and deliver to the Cooperative a Right-of-Way Easement to provide electric service to the Member in such form as may from time-to-time be used by the Cooperative, a copy of which shall be available at the office of the Cooperative.

While every effort has been made to ensure that the information provided in this document is accurate, REA Energy Cooperative, Inc. (REAC) or any of its affiliates does not accept liability or responsibility for (but not limited to) mistakes, inaccuracies, out of date information, errors, and omissions. No warranty, express or implied, is given for the information provided in this document.

2.0 DEFINITIONS

Unless the context clearly indicates otherwise, certain words and phrases when used in this booklet shall be defined as shown below. For additional definitions, see the latest edition of the National Electrical Code.

AMPACITY – Current carrying capacity expressed in amperes.

APPROVED – Indicates approval by REA Energy Cooperative.

CONCEALED METERS - Meters are concealed if they are located in areas such as but not limited to: enclosed porches, under decks, enclosed breezeways, inside a building, cabinets/enclosures, etc. Meters must be visible such that a prudent person can locate the meter while walking the perimeter of a building or service. Cooperative requires a minimum of 6' of clearance above finished grade for all meter locations.

COOPERATIVE – “REA Energy Cooperative” and the areas it serves.

MEMBER – Any present or prospective user of the Cooperative’s service.

FURNISHED AND INSTALLED BY THE COOPERATIVE – Either the Cooperative or an authorized contractor acting on its behalf shall provide labor and material for the items so specified.

FURNISHED BY COOPERATIVE, INSTALLED BY MEMBER – Materials so specified shall be provided by the Cooperative and be installed at the Member’s expense.

NEC – National Electrical Code, NFPA 70.

RUS – Rural Utility Services

SERVICE DROP – The overhead wires through which service is supplied between the Cooperative’s distribution facilities and the point of their connection to the Member’s service facilities located at the Member’s building or other support.

SERVICE LATERAL – The underground wires through which service is supplied between the Cooperative’s distribution facilities and the first point of their connection to the Member’s service facilities located at the building or other support.

SERVICE ENTRANCE – All components between the service point of the overhead service drop or underground service lateral and the Member’s main disconnecting means with the exception of the Cooperative’s metering equipment.

SERVICE ENTRANCE CONDUCTORS – The wires between the point of termination of the overhead service drop or underground service lateral and the Member’s main disconnecting device.

SERVICE POINT – Point of connection between the facilities of the Cooperative and the Member’s wiring.

RATES – The schedules of rates of the Cooperative.

TEMPORARY SERVICE – Service supplied for construction purposes or of limited duration and delivered to a single point through one meter.

WORK ORDER NUMBER – A unique number assigned by the Cooperative for the purpose of designing, tracking, constructing and billing a project.

3.0 ELECTRIC SERVICES AVAILABLE

The Cooperative only supplies alternating current at a nominal frequency of 60 Hertz (Hz) or cycles per second. The following table lists the standard voltages, 600 volts or less, which are available depending upon the Cooperative’s available facilities, method of service, and the size and character of the Member’s load:

Voltage	No. of Phases	No. of Conductors	Notes
120/240	1	3	
208/120	3 Wye	4	1
480/277	3 Wye	4	

Consult the Cooperative for availability of the following:

Voltage	No. of Phases	No. of Conductors	Notes
240/120	3 Delta	4	2
480	3 Delta	3	

NOTES:

1. Single-phase, 120/208 volt, 3-wire service, not exceeding 200 amperes, may be obtained for multi-family dwelling units where meters are grouped at one location. Meter sockets for such service require a fifth terminal (jaw) mounted in the 9 o'clock position for the neutral connection (see Figure 31).
2. This service voltage is not available for underground service energized from an underground primary source regardless of the source voltage. This service voltage is available from an overhead closed-delta or open-delta transformer bank energized from an overhead 12.47 kV and below primary source. Also, this service is available from an open-delta transformer bank with a maximum transformer capacity of 1-75 kVA and 1-25 kVA.

4.0 GENERAL REQUIREMENTS

4.01 APPLICATION FOR ELECTRIC SERVICE AND/OR MEMBERSHIP

Application for electric service and/or membership shall be made to and be accepted by the Cooperative before service will be supplied. Application can be made by contacting the Cooperative at 1-800-211-5667. Applications should be made, as far in advance as possible of the date service is required. Once commitment for electric service has been made, a Work Order number will be assigned by the Cooperative for the work (if necessary). The Member shall reference the Work Order number in all correspondence with the Cooperative. The Member shall consult the Cooperative for information concerning the point of attachment of the Cooperative’s service facilities to the Member’s building, the location of the meter, characteristics of service, and other pertinent matters before proceeding with the installation of the service entrance. **The standard overhead and underground electrical distribution utilized by the Cooperative is front lot construction.** Members shall also submit appropriate worksheet(s) as specified (see pages 54-58).

4.02 EXTENSION OF COOPERATIVE’S FACILITIES

Extension of the Cooperative’s facilities to serve a Member will be made in accordance with provisions of the Cooperative’s policy. The Cooperative will be pleased to discuss the terms and conditions of extending its facilities to supply service upon request.

4.03 REQUIREMENTS FOR A RESIDENTIAL STRUCTURE TO BE CONSIDERED A PERMANENT INSTALLATION

Masonry or Wood Structure (“Stick built” or Modular) Type Home

- (a) Directly connected to a public water system, water well, or other reasonable source of potable water meeting all applicable local requirements.

- (b) Directly connected to an approved septic system, a public sewage system, or an alternate sewage method meeting all applicable local requirements.
- (c) Containing a living area, kitchen, and bathroom.
- (d) Located on a permanent foundation.

Mobile or Manufactured Home

- (a) Directly connected to a public water system, water well, or other reasonable source of potable water meeting all applicable local requirements.
- (b) Directly connected to an approved septic system, a public sewage system, or an alternate sewage method meeting all applicable local requirements.
- (c) Wheels and axles removed.
- (d) Some type of permanent connection to the earth.

Note: The term connection as used in (d) above is a means for anchoring the mobile or manufactured home to earth, and does not refer to an electrical connection.

Vehicular-type units primarily intended as temporary living quarters, to include, but not limited to, recreational vehicles (“RV’s”), motor homes, travel trailers, truck campers, park trailers and camping trailers, shall not be considered as permanent.

Mobile or manufactured homes for purposes other than as a dwelling unit (i.e. on-site offices, mobile dressing rooms, banks, clinics, stores, or mobile displays) shall not be considered as permanent.

4.04 INSTALLATION AND RESPONSIBILITY

It is necessary for the protection of the Member that all work, wiring and apparatus be installed and maintained in a safe manner by a **qualified electrician**. A **qualified electrician** is one who has the skills and knowledge related to the construction and operation of the electrical equipment, systems and installations, and has received safety training to recognize and avoid the hazards involved. The Member, in accepting service from the Cooperative, assumes full responsibility for the safety of his or her wiring and equipment. A certificate of electrical inspection approval shall be required from a recognized electrical inspection agency. The Member agrees to indemnify and hold the Cooperative harmless from any liability that may arise as the result of the use of service supplied to the Member by the Cooperative.

The Member shall not operate any apparatus which creates a condition that interferes with the Cooperative’s operation and prevents the Cooperative from supplying satisfactory service to the Member or to other Members. This includes, but is not limited to, operating equipment which interferes with the satisfactory operation of other Members’ radio, television and communication equipment (see Section 4.14).

The Cooperative reserves the right to place restrictions on the type and manner of use of all the Member’s electrical equipment which is connected to the Cooperative’s lines, especially prohibiting any large loads that are highly fluctuating, high harmonic content, or low power factor characteristics.

4.05 MEMBER ALTERATIONS AND ADDITIONS

The Cooperative’s facilities used to provide service have definite capacity limitations and can be damaged by overloads. Therefore, the Member shall notify the Cooperative prior to increasing the load requirements or making alterations to the service entrance equipment so that facilities of proper capacity may be provided. At that time, the Cooperative may assign a Work Order number for the work. The Member shall reference the Work Order number in all correspondence with the Cooperative. Failure to properly notify the Cooperative of such additional requirements may result in damage to the Member’s and/or the Cooperative’s equipment. The Member shall be responsible for all expenses and/or damages to the Member’s, third parties, and/or Cooperative’s facilities resulting from failure to give proper notification. The Member may also be subject to charges by the Cooperative for work required to meet the Member’s alterations. The Member should contact the Cooperative for information concerning charges for such work. A certificate of electrical inspection approval shall be required from a recognized electrical inspection agency. Member shall also provide the completed appropriate

worksheet (see pages 55 and 57).

4.06 REQUIREMENTS OF ELECTRICAL INSPECTION

The Cooperative will supply service to new electrical installations when all the requirements contained in this book and the Cooperative's electric service policies have been met. Electrical installations requiring inspections include, but are not limited to the following:

- (a) New services, temporary services, mobile home feeders, service upgrades or modifications between meter socket service entrance equipment.
- (b) Service disconnected for more than one year.
 - "Service disconnected" INCLUDES cut and de-energized installations.
 - "Service disconnected" INCLUDES energized booted but inactive (no usage) installations.
- (c) When tampering resulting in a dangerous condition is detected.
- (d) Where the installation is deemed unsafe by the Cooperative.
- (e) When pole service equipment is replaced.
- (f) Inspections are not required when a main breaker only is replaced in like kind.

A certificate of electrical inspection approval shall be required from a recognized electrical inspection agency.

4.07 SWIMMING POOL LOCATION

For safety reasons, the Cooperative prohibits placing a swimming pool under its existing service drop or other conductors. Specifically, a swimming pool is not to be located within twenty-five (25) feet of the Cooperative's overhead conductors measured horizontally from the edge of the pool without written approval of the Cooperative. The Cooperative's primary and secondary underground cable shall not be installed within five (5) feet measured horizontally from the edge of the pool, decking, structures, or its auxiliary equipment.

4.08 BUILDINGS/STRUCTURES NEAR ELECTRIC LINES

Buildings and Structures (including signs, flag poles, light standards, antennas or aerials) shall not be installed under, over or in such close proximity to electric lines that they could be raised into or fall onto such lines or that they cannot be safely maintained. Antennas, aerials or satellite dishes shall not be attached to a Cooperative pole or any pole used in supplying electric service to the Member. NESC clearances shall be maintained. Consult the Cooperative for clearance requirements.

Fire hydrants shall be a minimum distance of four (4) feet from Cooperative facilities.

4.09 ATTACHMENTS ON COOPERATIVE-OWNED FACILITIES

Under no conditions will the Member's facilities or other equipment such as, but not limited to, signs, posters, or notices be installed on the Cooperative's poles or other property. Only approved service entrance equipment shall be attached to Cooperative secondary poles.

4.10 REQUESTED PROTECTION FOR PERSONS WORKING NEAR COOPERATIVE FACILITIES

Upon reasonable advance notification to the Cooperative, by an individual or contractor, that proposed work is to be performed within such distance of the Cooperative's facilities that could be hazardous for the person(s) performing the work, or may otherwise be in violation of federal or state regulations, the Cooperative will cover, de-energize, or temporarily move its facilities in the work area as it deems appropriate under the circumstances. The Cooperative may bill the notifying individual or contractor for the amount of its costs of performing such work. If circumstances require work outside normal work hours, costs for the overtime period will be computed and billed at overtime rates.

4.11 ACCESS TO MEMBER'S PREMISES (refer to Application for Membership and for Electric Service, and Cooperative By-Laws)

The Cooperative's authorized agents and employees shall have access to the Member's premises, only to the extent needed by the Cooperative for access to its property, for purposes necessary in connection with supplying and maintaining service, and upon termination of service shall be permitted to remove any or all such property. Authorized Cooperative employees and contractors visiting the premises of the Member for any purposes are furnished with an identification card. The Member should refuse admission to persons not having proper identification.

4.12 COOPERATIVE'S EQUIPMENT ON MEMBER'S PREMISES (refer to Application for Membership and for Electric Service, and Cooperative By-Laws)

The Member shall provide, without cost to the Cooperative, satisfactory right-of-way and suitable location and housing for the Cooperative's equipment which is necessary for supplying service to the Membership.

4.13 COOPERATIVE'S RESPONSIBILITY (refer to Application for Membership and for Electric Service, and Cooperative By-Laws)

The Cooperative will use reasonable diligence in providing reliable electric service. However, the Cooperative shall not be liable for any loss, cost, damage or expense to any Member occasioned by any failure to supply electricity according to the terms of the Membership Agreement, or by an interruption or reversal of the supply of electricity, if such failure, interruption or reversal shall be due to the elements, public enemies, strikes or order of Court, which are beyond the control of the Cooperative, or any cause except willful default or neglect on its part. Unless caused by an unreasonable practice of the Cooperative, the Cooperative may, without liability, interrupt or limit service to any or all Members whenever, in the sole judgment of the Cooperative, such action is necessary in order to prevent or limit any actual or threatened instability or disturbance on the electric system of the Cooperative or any electric system interconnected with the Cooperative. Members should be aware that they could occasionally experience intermittent power interruptions. Since most interruptions are temporary, the Cooperative designs its electrical system to clear these intermittent interruptions without permanently interrupting electric service.

4.14 RIGHT TO REFUSE OR DISCONTINUE SERVICE

Since it is the Cooperative's obligation to provide safe and satisfactory service to all Members, the Cooperative reserves the right to refuse or discontinue service without notice if, in the opinion of the Cooperative, the Member's wiring, equipment or appliances are unsafe for receiving electric service or are harmful to the service of other Members. The Cooperative will make a reasonable effort to notify the Member prior to disconnection and shall inform the Member of the steps that shall be taken to have service restored. The Cooperative reserves the right to refuse or discontinue service with or without notice, and without liability, under various circumstances other than those mentioned above. These circumstances are set forth in the Cooperative's By-Laws and policies as approved by its Board of Directors.

4.15 STAND-BY GENERATOR SERVICE

The generator and all wiring installations connecting the generator to the Member's wiring shall be installed in accordance with the NEC. The Member assumes full responsibility for the installation and safe operation of the generator. The Cooperative reserves the right to discontinue service to the Member, without notice, any time it is discovered that the generator is improperly connected to the Member's circuits or is otherwise unsafe. **ABSOLUTELY NO GENERATOR SHALL BE INSTALLED WITHOUT A PROPER TRANSFER SWITCH.** See policy C-30 for more information or contact our subsidiary REA Energy Services, Inc. for sales and expert installation at 724-349-4800.

4.16 TRANSFORMER FOUNDATIONS

The Cooperative does not permit installation of transformers in a building.

Members shall secure foundations specifications from Cooperative and consult Cooperative regarding

the location and construction of transformer foundations while building plans are being prepared.

5.0 OVERHEAD SERVICE REQUIREMENTS (600 VOLTS OR LESS)

5.01 GENERAL

Members desiring overhead service shall contact the Cooperative, prior to the start of construction, to obtain the point of service drop attachment at the Member's building or other support, type of metering facilities to be used, cost and other information relative to this type of service.

The Cooperative will provide overhead electrical service in accordance with its requirements for overhead extension. The standard overhead and underground electrical distribution utilized by the Cooperative is front lot construction. The Cooperative shall provide service from facilities located along public roadways that the Cooperative has a legal right to occupy or on public lands and private property across, which satisfactory rights-of-way or easements may be obtained.

If the Cooperative requests, the Member shall furnish the Cooperative, at no charge, property plats, utility plans, grading plans, roadway profiles, load requirements and other items showing details of proposed construction in a reasonable time to allow the Cooperative to engineer, design, acquire materials and construct its facilities in a safe, efficient manner.

The Member must provide a safe and suitable access for Cooperative personnel to the location of meter socket and service facilities if foundation is not backfilled.

The Member shall provide all rights-of-way, easements and local, state, and federal governmental agency permits required for service on the Member's owned or leased property prior to the Cooperative installing its facilities. The Member will assist the Cooperative in obtaining all rights-of-way, easements and permits required for service beyond the Member's property.

5.02 SERVICE DROP

The Cooperative shall provide, install, own and maintain the service drop conductors from the overhead distribution system to the point of attachment to the Member's overhead service entrance (as designed by the Cooperative).

The Member shall provide and maintain a safe, substantial support for the Cooperative's overhead service connections. In no case will the Cooperative be responsible for the condition of any Member's building or structure to which service conductors are attached, unless caused by an unreasonable practice of the Cooperative. Cinder blocks, stucco, veneered and similar type walls usually require Cooperative approved anchor bolts, or other acceptable means of support for termination of the service drop. Parapet walls and chimneys are not acceptable supports. The Cooperative reserves the right to approve or deny alternate support designs.

The service drop will not cross over property other than that of the Member to be served unless the Cooperative has obtained or received written consent from the owner of such property.

The service drop should not be installed over buildings or swimming pools. If the service drop must be installed over buildings, NESC clearances shall be maintained. Refer to Section 4.07 for required swimming pool clearances. **Trees should not be planted under service and primary conductors.**

The Cooperative shall not be required to furnish or install more than one service drop for each building served. However, exceptions to this rule will be made if written Cooperative approval is obtained prior to proceeding with any work and any of the following conditions are met:

- (a) Where required for types of service of different phase or voltage.
- (b) Where required by law.
- (c) Where required for fire pumps or emergency lighting or public safety regulations.
- (d) Where a single property extends over an area that makes it impractical to serve through one service drop.

- (e) Where the Cooperative needs more than one service drop to supply the Member's load requirements.
- (f) Where multi-occupancy buildings have no common locations for service equipment that is accessible to all occupants.

5.03 SERVICE ENTRANCE

The Member shall provide, install, own and maintain the complete service entrance when supplied from an overhead service drop, including the meter socket. In addition, the Member shall supply, install, own and maintain all material located on the load side of the service entrance disconnect.

Where required, all transformer-operated metering enclosures (including current and voltage transformers) shall be furnished and installed by the Cooperative (see Section 8.06). For remote metering communications requirements, see section 8.08.

The service entrance conductors shall be sized for calculated loads or main breaker to meet the requirements of the NEC and any other applicable codes. The service entrance conductors shall not be spliced. Service entrance cables or service entrance conduits on buildings, poles or structures shall not be concealed or recessed.

The Member's service entrance shall have a minimum of two driven ground rods (8 feet minimum length) at least six (6) feet apart. The grounding electrode conductor shall be continuous from the service entrance main disconnect to both driven ground rods. The Member shall install the service entrance in such a manner to ensure that all of the grounding/ bonding requirements of the NEC are met or exceeded.

5.04 CONNECTIONS BETWEEN COOPERATIVE'S AND MEMBER'S FACILITIES

The connections between the Cooperative's and the Member's facilities shall be made only by authorized employees of the Cooperative. The Member's installation shall be completed and any required inspections obtained prior to the Cooperative installing its facilities (see Section 4.06).

The Member will be responsible for connecting all service entrance conductors to any form of Member-owned disconnecting devices or equipment. In cases involving large service drops, or parallel services, the Cooperative will advise the Member sufficiently in advance of the time when service is required concerning the number, size and type of the Cooperative's conductor(s). The Member will also be responsible for ensuring that the main disconnect or terminal box has the proper number and size of terminals and that the connected loads are balanced among phases and sets of conductors.

Service conductors to the point of attachment larger than 4/0 aluminum conductor will be required to be furnished and installed by the member. All secondary connectors that are larger than 4/0 will be provided by the member. All service conductors 4/0 or less will be furnished and installed by the Cooperative.

When the Member's load necessitates parallel service entrance conductors, the Member shall furnish and install suitable equipment to allow the Cooperative to connect the service drop with a single set of attachments (see Figures 10 & 33).

5.05 PERMANENT OVERHEAD SERVICE INSTALLATIONS

A typical permanent overhead service installation is shown in Figure 3. The service drop support provided by the Member shall be installed in such a manner to maintain the clearances specified in Figure 1. If the Member's building is not of sufficient height to provide for the clearances required, the Member shall provide a support for attaching the Cooperative's service drop similar to that shown in Figure 3.

5.06 TEMPORARY OVERHEAD SERVICE INSTALLATIONS

A typical temporary overhead service installation is shown in Figure 4. The service drop support

provided by the Member shall be installed in such a manner to maintain the clearances specified in Figure 1.

5.07 MOBILE/MANUFACTURED HOME OVERHEAD SERVICE INSTALLATIONS

A typical mobile home overhead service installation is shown in Figure 5. Upon Cooperative approval, a combination meter socket/disconnect enclosure may be used for this type of installation. The Cooperative also has a program for its members to pay a fee and have the disconnect enclosure supplied and installed. Contact REA Energy Services, Inc. for the most current program and fees offered by the Cooperative.

A manufactured home is considered a mobile home if any of the following conditions exist:

- (a) Located in a mobile home park.
- (b) If it is not installed on a permanent foundation or foundation that meet the requirements of local building codes. A permanent foundation can be either a perimeter with concrete blocks or poured concrete.
- (c) If it does not have a manufacturer's sticker to indicate that the home is manufactured in accordance with government specifications (Part 3280, *Manufactured Home Construction and Safety Standards*, of the Federal Department of Housing and Urban Development).

If none of the above conditions exist, a manufactured home can either have an overhead or underground service entrance and meter socket installed on the outside of the home.

5.08 RECREATION VEHICLE SERVICE INSTALLATIONS

For service to an individual Recreational Vehicle or Recreational Vehicle park, the applicable requirements should adhere to the current edition of the NEC.

5.09 CENTRAL DISTRIBUTION SERVICE INSTALLATIONS (FARM POLE)

A farm or commercial operation with specific load requirements may have service from a Cooperative-owned central distribution pole to which the Cooperative will extend its overhead secondary service drop. Figure 7a provides the specific details for this type of installation. When the Member elects to utilize an emergency generator, the Member's facilities shall be arranged as shown in Figures 7b & 8.

5.10 SMALL NON-RESIDENTIAL SERVICE INSTALLATIONS

For installations such as billboards, lights, signs, bus shelters, phone booths, etc., which only have one or two branch circuits serving the load, refer to the current edition of the NEC.

The service supplied to non-residential service installations shall be 120/240V, 3-wire. The minimum meter socket size in all cases will be 100 amps, and the service entrance conductors shall be sized for the calculated load or main breaker. All other applicable sections of this document shall apply, including attachment point heights, clearances, grounding, inspection requirements, notifications, Work Order numbers, etc.

5.11 OVERHEAD SERVICES IN EXCESS OF 600 VOLTS

The Member shall contact the Cooperative if a service voltage in excess of 600 volts is required.

6.0 UNDERGROUND SERVICE REQUIREMENTS

6.01 GENERAL

Members desiring new underground service or modifications to existing underground service, shall contact the Cooperative prior to the start of construction to obtain the point of service lateral attachment at the Member's building or other support, type of metering facilities to be used, cost and other information relative to this type of service.

The length, nature and route of an underground service lateral shall be governed by good engineering practices and shall be installed in such a manner that they are free of drainage fields, septic systems, pipes, water and gas lines, areas of deep cultivation and other interference. **Shrubs and trees should not be planted within the underground service rights-of-way.**

The Member shall provide all rights-of-way, easements and local, state, and federal governmental agency permits required for service on the Member's owned or leased property prior to the Cooperative installing its facilities. The Member will assist the Cooperative in obtaining all rights-of-way, easements and permits required for service beyond the Member's property. The Member shall be required to clear the service lateral route of trees, tree stumps and other obstructions and prepare rough grade to within six (6) inches of final grade on the Member's property prior to the Cooperative installing its facilities. If the Member performs any future modifications, (such as grading, building additions, swimming pools, etc.) that will require the service lateral to be relocated, the Member shall pay for this relocation.

The Cooperative shall control the initial and subsequent use of the trench and its backfill. At the Cooperative's option, communication utilities such as telephone and CATV, may share the trench. No separation between the Cooperative's cables and telephone or CATV facilities is required by the Cooperative when the cables are installed in conduit. Telephone and CATV companies may have requirements for separation. Joint trench with gas, water or sewer shall be avoided unless local conditions or regulations require the use of a shared trench. If shared trenching is required by regulations, gas, water and sewer lines may share the trench provided a twelve (12) inch minimum horizontal separation is maintained between the gas, water, sewer and electric lines; however, **greater separation** should be maintained where practical. Local gas, water and sewage companies may require further separation. Member's private lines are not permitted to be placed in trenches provided for Cooperative use.

The Cooperative will provide underground electrical service in accordance with policies and By-Laws for underground extension.

The standard overhead and underground electrical distribution utilized by the Cooperative is front lot construction. The Cooperative shall provide service from facilities located along public roadways that the Cooperative has a legal right to occupy or on public lands and private property across which satisfactory rights-of-way or easements may be obtained.

If the Cooperative requests, the Member shall furnish the Cooperative, at no charge, property plats, utility plans, grading plans, roadway profiles, load requirements and other items showing details of proposed construction in a reasonable time to allow the Cooperative to engineer, design, acquire materials and construct its facilities in a safe, efficient manner.

The Member must provide a safe and suitable access for Cooperative personnel to location of meter socket and service facilities if foundation is not backfilled.

6.02 SERVICE LATERAL (RESIDENTIAL)

The Member shall provide a location suitable to the Cooperative for the required pad-mounted transformer(s) and other devices. Such location shall be free from obstructions and, where required, the Member shall furnish and install protection from vehicular traffic as shown in Figure 26. The Cooperative will furnish and install single-phase, pad-mounted transformer foundation(s). For services to multi-family residential buildings that require 3-phase services, the Member shall furnish and install 3-phase pad mounted transformer foundations in accordance with the Cooperative's specifications (see Figures 24 and 27).

When the Member decides to install shrubs to shield a pad-mounted transformer or other pad-mounted equipment, see Figure 25. The Member is warned that pad-mounted transformers and pad-mounted equipment have underground electric cables entering and exiting them below grade. **State law requires the Member to call the toll free number to have the underground cables located before digging (see Section 6.10).** The Cooperative accepts no responsibility for damage to Member-owned

shrubs resulting from maintenance of Cooperative-owned facilities.

The Member shall provide, at his expense, all necessary excavating and backfill and shall furnish and install the service lateral conduit. The Cooperative shall own and maintain all service lateral facilities, including the service lateral facilities installed by the Member. The Cooperative will specify the type and size of the conduit to be installed. Also, the Member shall install a pulling rope as specified by the Cooperative to install its underground conductors. Final acceptance of all work performed by the Member shall be determined by Cooperative personnel subsequent to the installation of the Cooperative's facilities. The Cooperative reserves the right to refuse service until the Cooperative's standards and specifications have been met.

6.03 SERVICE LATERAL (COMMERCIAL OR INDUSTRIAL)

The Member shall provide a location suitable to the Cooperative for the required pad-mounted transformer(s) and other equipment. Such location shall be free from obstructions and, when required, the Member shall furnish and install protection from vehicular traffic as shown in Figure 26.

For single-phase installations;

- (a) For services that are 400 amp or less the Cooperative will furnish and install single-phase pad-mounted transformer foundation(s) and conductors (see Figures 24- 27).
- (b) When the metering is located on the Member's building or structure, the Cooperative will provide and install all service lateral conductors to the point of metering. Member shall provide, for the Cooperative's use, all necessary excavating and backfill and shall furnish and install the service lateral conduit. The Cooperative will specify the type and size of the conduit to be installed. Also, the Member shall install a pulling rope as specified by the Cooperative to install its underground conductors. The Cooperative shall own and maintain all service lateral facilities to the point of metering, including the service lateral conduit installed by the Member.
- (c) When the metering (transformer-rated) is located at the Cooperative's pad-mounted transformer, the Member shall provide all necessary excavating and backfill and shall furnish, own, install, and maintain the service lateral conduits and conductors. The Member shall furnish, own, install, and maintain a Cooperative-approved meter socket mounting structure within five (5) feet of the transformer and install a 1-1/4" IMC or rigid metallic conduit between the transformer and the meter socket.

For three-phase installations;

- (a) The Member shall furnish and install three-phase, pad mounted transformer foundation(s) in accordance with the Cooperative specifications (see Figures 24-27).
- (b) For three-phase service lateral installed in conduit, the conductors shall be installed as A-B-C-N in each conduit, rather than segregated by phases. Conductors shall be color-coded according to NEC requirements.
- (c) When services are 400 amps or less and the service lateral is no larger than 4/0 aluminum, and the metering is located on the Member's building or structure, the Cooperative will furnish and install all service lateral conductors to the point of metering. Member shall provide, for the Cooperative's use, all necessary excavating and backfill and shall furnish and install the service lateral conduit. Also, the Member shall install a pulling rope as specified by the Cooperative to install its underground conductors. The Cooperative shall own and maintain all service lateral facilities to the point of metering, including the service lateral conduit installed by the Member. For transformer-rated meter installations – refer to Section 8.06.
- (d) When the metering is located at the Cooperative's pad-mounted transformer (preferred), the Member shall provide all necessary excavating and backfill and shall furnish, own, install, and maintain the service lateral conduits and conductors. For transformer-rated metering at pad-mounted transformer, refer to Section 8.07.
- (e) Service conductors to the point of attachment larger than 4/0 aluminum conductor will be required to be furnished and installed by the member. All secondary connectors that are larger

than 4/0 will be provided by the member.

(f) For metering communications, refer to Section 8.08.

6.04 SERVICE ENTRANCE

The Member shall provide and install, own and maintain the complete service entrance from the weatherhead to the service disconnect. In addition, the Member shall supply, install, own and maintain all material located on the load side of the service entrance disconnect.

Where required, all transformer-operated metering enclosures (including current and voltage transformers) shall be pre-wired, furnished and installed by the Cooperative (see Section 8.06).

The service entrance conductors shall be of sufficient ampacity to meet the requirements of the NEC and any other applicable codes. The service entrance conductors shall not be spliced.

The Member's service entrance shall have a minimum of two driven ground rods (eight (8) feet minimum length) at least six (6) feet apart. The grounding electrode conductor shall be continuous from the service entrance main disconnect to both driven ground rods. The Member shall install the service entrance in such a manner to insure that all of the grounding/bonding requirements of the NEC are met or exceeded.

6.05 CONNECTIONS BETWEEN COOPERATIVE'S & MEMBER'S FACILITIES

The connections between the Cooperative's and the Member's facilities shall be made only by authorized employees or contractors of the Cooperative. The Member's installation shall be completed and any required inspections obtained prior to the time the Cooperative installs its facilities (see Section 4.06).

The Member will be responsible for connecting all service entrance conductors to any form of Member-owned disconnecting devices or equipment. In cases involving underground service laterals, or parallel services, the Cooperative will advise the Member sufficiently in advance of the time when service is required concerning the number, size and type of conductor(s) the Cooperative will use. The Member will also be responsible for ensuring that the main disconnect or terminal box has the proper number and size of terminals to accept the Cooperative's conductors and that loads shall be so connected as to be balanced among phases and sets of conductors.

The Cooperative will be responsible for making all connections to its power transformer or metering transformers regardless of whether involved conductors are Cooperative or Member owned. The Cooperative will connect its service lateral to the Member's service entrance. For **commercial or industrial** Members, the Member will furnish and the Cooperative will install the connectors necessary to connect the Member's service lateral to the Cooperative's pad-mounted transformer. The Member shall provide sufficient length of conductor for Cooperative to make required bends and connections.

6.06 PERMANENT UNDERGROUND SERVICE INSTALLATION

Typical permanent underground service installations are shown in Figures 20, 21, and 23. The service lateral shall be installed in such a manner to maintain the clearances as shown.

6.07 TEMPORARY UNDERGROUND SERVICE INSTALLATION

A typical temporary underground service installation is shown in Figure 22.

6.08 MOBILE/MANUFACTURED HOME UNDERGROUND SERVICE INSTALLATION

A typical mobile home underground service installation is shown in Figure 21. The Member will be required to provide a suitable support (as specified by the Cooperative) for the Cooperative's metering facilities. If a meter pole is used for support, the Member will be responsible for any contribution in aid as required by the Cooperative. The location of this support shall be subject to Cooperative approval. In addition to the installation shown in Figure 21, when a combination meter socket/disconnect or load

center is used as service equipment for any mobile home the following shall apply:

The line side lugs of the meter socket shall be factory wired or bussed to a location in or below the disconnect or load center and allow the service lateral conductors to terminate without bending or passing over top of or around other equipment or terminations, unless there is a wireway provided in the disconnect to provide service lateral access to line side of meter(s).

To determine whether or not a manufactured home is considered a mobile home, refer to items (a) through (c) in Subsection 5.07.

Note: The Cooperative can supply and install a meter disconnect switch for a fee. Contact REA Energy Services, Inc. for current pricing.

6.09 UNDERGROUND SERVICE INSTALLATIONS IN EXCESS OF 600 VOLTS

The Member shall contact the Cooperative if a service voltage in excess of 600 volts is required.

6.10 EXCAVATION NEAR UTILITY UNDERGROUND FACILITIES

For safety to persons, property, or to prevent loss of service to the public, the person(s) planning to excavate shall **mark the area to be excavated with white paint** and call the telephone number listed below for assistance in locating and marking underground facilities. This call shall be made at least 72 hours, not including weekends and holidays, in advance of the planned excavation.

PENNSYLVANIA: "Pennsylvania One-Call" (1-800-242-1776 or 811)

Excavation shall not begin until excavator has been notified:

- (a) That the line location has been marked by stakes, paint, or other suitable identifying means as indicated below: within 18 inches on either side horizontally from the outside wall of such line.
- (b) That in extraordinary cases, if the utility cannot mark within 2 working days, it will notify the person proposing to excavate of this fact and will advise the person of the date and time when the underground facility will be marked.
- (c) That a utility's underground facilities are not within the area of proposed excavation and therefore do not have to be marked.

In the event excavation uncovers buried electrical cables, conduits, or warning tape with the following message "**CAUTION—BURIED ELECTRICAL LINE BELOW,**" please discontinue excavation immediately and notify the Cooperative (1-800-211-5667).

The National Call Before You Dig Hotline number (811) is available to request underground location in many states.

7.0 MEMBER EQUIPMENT

7.01 GENERAL

The Member shall notify the Cooperative prior to adding or upgrading electrical equipment so that facilities of proper capacity may be provided to assure satisfactory operation of the Member's equipment and to protect both the Member's and the Cooperative's equipment against damage. The Member is required to provide protection that will prevent damage to equipment from normal operations of the Cooperative's supply system. This equipment includes (but is not limited to) motors, welders, heating equipment, voltage sensitive devices, harmonic producing equipment, x-ray equipment, and other equipment that may require special starting and protection.

7.02 MOTOR INSTALLATIONS

It is characteristic for most motors to draw a heavy momentary current on starting. The starting current for Alternating Current (AC) motors can be on the order of three to ten times the normal running current. If sufficient capacity is not present in the Member's circuits and in the Cooperative's facilities

serving them, the motor may not start properly, resulting in overheating, blown fuses or damage to the motor and other equipment. In addition, it may result in excessive voltage fluctuations and light flicker that may be objectionable to the Members using the motor, as well as to other Members supplied from the same lines. It is, therefore, necessary for the Cooperative to place restrictions on the starting current of a motor either by limiting the size of the motor or by requiring the Member to install suitable starting devices.

Motors installed should be suitable for operation at the service voltage available. The Member shall consult the Cooperative (1-800-211-5667) prior to purchasing or installing any motor to verify the voltage, frequency and phase characteristics of the services to be supplied, the capacity available, and the suitability of the proposed equipment for operation at the intended location.

The following maximum permissible motor starting currents shall apply to the installation of motors:

Equipment for Operation at:	Total Locked Rotor Current Not to Exceed:
Single-Phase	
120 volts	50 amp
240 volts	
2 hp or less	60 amp
2 hp to 6.5 hp	60 amp plus 20 amp per hp in excess of 2 hp
Over 6.5 hp	Consult Cooperative*
Three-Phase	
240 volts**	
2 hp or less	50 amp
2 hp to 19.9 hp	50 amp plus 14 amp per hp in excess of 2 hp
Over 19.9 hp	Consult Cooperative

*Upon proper application, the Cooperative will investigate the possibility of serving single-phase capacitor start, capacitor run motors larger than 6.5 hp where such service does not adversely affect our Members. **Member shall supply a Motors Specification Worksheet (page 58).**

****Three-phase supply is not available for residential rate schedule service.**

For poly-phase motors and equipment to be operated at voltages other than 240 volts, the locked rotor currents specified for 240 volts shall be multiplied by the inverse ratio of the voltages.

Where equipment, ratings or starting characteristics other than those covered in the preceding table are being considered, the Cooperative will furnish information regarding higher starting currents for single-phase motors and 3-phase motors which will be permitted under specific conditions. Permissible starting currents will depend upon the size of the motor, the frequency of the starting, the character of the Member's load, and the design and capacity of the Cooperative's supply system in the area. Generally, this will be equivalent to the maximum starting current that, in the Cooperative's opinion, can be supplied without causing undue interference with service to other Members. Whenever a starting current that is not covered in the preceding table causes undue interference with service to other Members, the Member shall provide a starting device of a type that will reduce the starting current to the value required to eliminate such interference. **Service may be disconnected until corrections are made.**

The Member shall contact the Cooperative prior to the installation of any Direct Current (DC) motor or adjustable speed drive.

7.03 REQUIRED EQUIPMENT PROTECTION

It is the **Member's responsibility** to provide protection in accordance with the Member's requirements

and any applicable codes.

Specifically, the use of phase-failure and phase-reversal relays, are **required** on all new poly-phase motor installations. It is also highly recommended that existing poly-phase motor installations be retrofitted with phase-failure and phase-reversal relays to protect the motors from damage. Single-phasing conditions in the electrical supply system may damage motors. The Member has several options to provide phase-failure and phase-reversal protection. Some of the options are as follows:

- (a) One phase-failure and phase-reversal device may protect single motor or a group of motors.
- (b) The phase-failure and phase-reversal device can be installed on each motor and open all motor contacts and/or the device can activate an alarm to alert the Member that a phase-failure or reversal condition exists.

The Cooperative will not be responsible in any way for damage to the Member's equipment that is due to failure of the Member to provide adequate protection.

7.04 AIR CONDITIONERS, CENTRAL SPACE HEATING, HEAT PUMPS, INCLUDING SUPPLEMENTAL HEATING ELEMENTS IN HEAT PUMPS

Thermostatically controlled electric furnaces, boilers, and supplemental resistance heating elements in heat pumps with an installed capacity greater than 12kW shall be switched in increments at minimum intervals of 10 seconds.

For installations greater than 24kW, the Cooperative shall be consulted to determine staging parameters, unless switching can be accomplished in stages of 6kW.

A Member, installing a heat pump or air conditioner, in excess of 3 ton (single-phase) or 10 ton (three-phase), shall contact the Cooperative prior to installation of the equipment. Manufacturer's specifications for this equipment shall be provided to the Cooperative for review.

7.05 ELECTRIC WATER HEATERS

The heating elements of residential electric water heaters and tank-less water heaters shall be limited to a maximum of 5,500 watts each, shall be 208 or 240 volts, thermostatically controlled and connected to prevent simultaneous operation. All water heaters shall be equipped with an American Standards Association approved pressure-temperature relief valve located in the top of the tank, a two-pole, manual reset over-temperature cutoff switch with 190F maximum cutoff of electric supply and UL listed. Water heater elements exceeding these parameters may cause excessive flicker to Member.

The Cooperative shall be consulted before installing electric water heating equipment with heating elements in excess of 5,500 watts. The Cooperative is not responsible for unsatisfactory service resulting from the operation of such water heaters installed by Member without consulting Cooperative. When the installation of residential electric water heating equipment with heating elements in excess of 5,500 watts requires additional facilities, Member shall pay the costs of additional facilities beyond those facilities normally furnished by the Cooperative.

7.06 ELECTRIC WELDING, X-RAY, RADIO, ELECTRONIC EQUIPMENT, ETC.

Electric welding equipment shall not be connected to the Cooperative's lines without first consulting the Cooperative. Electric welding equipment may cause serious flicker in the Member's lighting as well as that of other neighboring Members. On rural lines and urban residential distribution systems, welding equipment shall be limited to a maximum of 50 amperes when supplied at 240 volts. A transformer-type welder is recommended for use on the Cooperative's lines. Straight resistance line voltage welders are not acceptable. Electric apparatus (such as X-ray equipment, radio, television and electronic transmitting equipment, and other electronic applications), which have an adverse effect on the Cooperative's ability to supply adequate service to all its Members, shall not be installed on and operated from the Cooperative's lines until the Member has secured specifications and available capacity from the Cooperative.

7.07 LIGHTNING AND SURGE PROTECTION

The Cooperative provides protection on its lines to minimize damage from lightning. The Cooperative will not be responsible for damage to Member's equipment because the Member did not provide adequate lightning or surge protection or due to the failure of any such devices. Whole house surge suppressors are available through REA Energy Services, Inc.

7.08 THREE-PHASE CONVERTER

Phase converters may be used to supply energy to 3-phase motors from a single-phase service. 3-phase motors served from phase converters may cause serious flicker in the Member's lighting or adversely affect the operation of other equipment in the Member's premises. The phase converter shall be sized properly for the load to be served in order to minimize the magnitude of voltage fluctuations caused by motor starting. The Cooperative shall be consulted before a phase converter is installed to ensure that its operation will not affect other neighboring Members. The Cooperative reserves the right to refuse service to a phase converter installation if it is determined that it would adversely affect the Cooperative's ability to supply adequate service to all its Members.

8.0 METER INSTALLATIONS

8.01 GENERAL

Meters and meter testing devices are furnished, installed and maintained by the Cooperative. They remain the property of the Cooperative and shall not be moved or the connections changed by any person other than authorized employees or contractors of the Cooperative.

All metering shall be installed on the line side of the Member's main disconnecting means except where the NEC requires a main disconnect ahead of a group of more than six (6) meters. See Figure 33 for self-contained, 480Y/277 volt, 4-wire metering installations. Consult Cooperative prior to purchasing or installing equipment.

Meter sockets, metering transformer cabinets and all other enclosures and switchboxes installed on the line side of the meter shall be equipped with provisions to accept a Cooperative meter seal before connection will be made by the Cooperative. Meter sockets, transformer cabinets, and other meter service enclosures are not to be used by the Member as junction boxes—only service entrance conductors are permitted. Metered and unmetered conductors shall **not** be installed in the same conduit, enclosure or raceway. Any energized meter socket must be properly covered at all times when the meter is not in place. Meter sockets and service conduits shall **not** be recessed into the wall. Unmetered service entrance cables or service entrance conduits on buildings, poles or structures shall not be concealed or recessed.

Meter installations that have the meter socket as part of a pedestal, multi-metered equipment, or attached to or an integral part of Member-owned service equipment shall be approved by the Cooperative prior to purchase and installation by the Member.

The Cooperative, in accordance with the rate schedule selected and the type of service supplied, determines the capacity and type of meter installation to accommodate the Member's load.

8.02 METER LOCATIONS

The Member shall provide space for the installation of the Cooperative's meters and equipment at an outside location designated by the Cooperative.

For residential single-family, duplex and townhouse dwellings, the meter socket shall be located outside within 15 feet of the nearest corner of the dwelling to the Cooperative facilities. If this location is not feasible due to physical obstructions, such as garage doors or windows, the Cooperative will choose an alternate location closest to its service facilities (see Figure 30).

The meter socket shall be installed so that the top of the socket is not more than 6' or bottom less than

3'-0" above the finished grade. Meter socket height for pedestals, multi-metered equipment, or meter sockets attached to or an integral part of Member-owned service equipment shall be approved by the Cooperative. The Member shall provide at least 15" of clear space on all sides of the meter as well as 36" in front of the meter. The above clearances shall be maintained regardless of structural changes of the building. The Cooperative will not accept a meter to be located in an area which could be dangerous to meter readers or testers, or where conditions would prevent the meter person from standing in front of the meter to test or read. Meters, meter sockets and metering transformers shall not be located in a manhole or any similarly classified location. **Meters shall not be concealed in areas, such as, but not limited to: enclosed porches, under decks, enclosed breezeways, inside a building, cabinets/enclosures, etc. Meters must be visible such that a prudent person can locate the meter while walking the perimeter of a building or service. Cooperative requires minimum of 6' of clearance above finished grade for all meter locations.**

An overhead meter service shall not be located on a Member-owned pole. Any metering installation on a Cooperative-owned pole shall be approved by the Cooperative.

If changes are made on the premises, thereby making the existing meter location unsafe, concealed, or inaccessible for reading or testing, the Member shall be required to make the necessary changes to correct the situation to avoid disconnection.

8.03 METER RELOCATIONS

When alterations or additions to a building or its wiring require a change in meter location, the Member shall notify the Cooperative before proceeding with any work. The Member may be responsible for the Cooperative's costs for facility modifications. The Member shall be responsible for all costs incurred in moving the socket and wiring.

8.04 EMERGENCY METER REMOVAL

Firefighters and other emergency personnel **SHOULD NOT** remove electric meters during fires or other emergencies. Removing a meter **MAY NOT** de-energize the building or contribute to the safety of firefighters or emergency personnel. All meters must be easily accessible and visible to the Cooperative. Call the Cooperative at 724-349-4800 for meter removal.

8.05 GROUP METER INSTALLATION

In serving groups of residential or commercial installations, provisions may be made to group meters at a single location that will be accessible to the tenant and to the Cooperative (see Figures 32 & 33).

The Member is responsible for permanently labeling each meter socket with its corresponding apartment, office, etc. being served. Labeling shall be by stenciled paint, engraving, stamping or riveted metal tag. When it is necessary that the Member to install a main/service disconnecting means because of the number of meters, this disconnecting means shall be sealed by the Cooperative.

8.06 TRANSFORMER-RATED METER INSTALLATIONS

Provisions shall be made for the installation of metering transformers for single-phase or 3-phase services in excess of 320 amperes. Metering transformers are normally installed on the line side of all service protective equipment, except where the NEC requires a main disconnect ahead of the metering.

When overhead service is provided, the metering transformer(s) will normally be of the outdoor-type and mounted sufficiently high, on the outside of the building, so that a transformer enclosure is not required (see Figures 11 & 34).

Sufficient access and working space shall be provided and maintained for all metering equipment. The meter socket shall be located outside and be mounted so that the top of the socket is 6' maximum and bottom is 3' minimum above finished grade and within 30' (cable length) of the current transformers.

If changes are made on the premises, thereby making the existing meter location unsafe, concealed, or

inaccessible for reading or testing, the Member shall be required to make the necessary changes to correct the situation to avoid disconnection.

Member-owned equipment **shall not** be connected in the secondary metering circuit without prior Cooperative approval.

8.07 TRANSFORMER-RATED METERING AT PADMOUNTED TRANSFORMER

The preferred location for transformer-rated metering will be at the Cooperative-owned, pad-mounted transformer. The Member shall be required to provide all facilities on the load side of the metering. For remote metering communication requirements see Section 8.08. The Cooperative shall be consulted regarding necessary space requirements and equipment to be furnished and installed by the Member.

8.08 METERING COMMUNICATIONS IF APPLICABLE

The Cooperative may require remote communication of metering when the assigned rate schedule deems interval metering is required. When the Cooperative deems remote communication is required, the following shall apply:

- (a) Transformer Rated Metering At Pad-Mounted Transformer - Member shall furnish and install a 1-1/4" conduit and approved pulling rope from the secondary compartment of the pad-mounted transformer to a location at the Member's building where telephone line service can be made available at the telephone demarcation point. Once the conduit from the pad-mounted transformer enters the building, cable may be used to the demarcation point or the conduit may be continued to the demarcation point (See Figures 23). **Consult Cooperative for details prior to installation.**
- (b) Transformer Rated Metering – Cabinet or Channel Package - Member shall provide access (cable or conduit) to the telephone facilities (demarcation point) within 5 feet of the meter socket on the same wall surface exclusively for Cooperative remote metering purposes. Conduit shall be a minimum 1-1/4" diameter, with approved pulling rope from the meter point to the telephone facilities (See Figure 34). **Consult Cooperative for details prior to installation.**

8.09 SEALS

The Cooperative will seal all meters and points of access to the wiring, ahead of the meter. All cabinets, switchboxes, terminal boxes, etc., which contain unmetered wires, shall be made sealable by the Member before service will be supplied. Where equipment is not arranged for sealing, 1/4" diameter holes shall be provided by the Member for sealing purposes. All service entrance conduit fittings used outside the building ahead of the meter shall have non-removable covers. The Cooperative prohibits the **breaking** of Cooperative seals by unauthorized persons, or tampering with meters or with any wiring equipment located ahead of the meter. Tampering with said equipment may result in prosecution or pose a serious safety risk.

9.0 METER SOCKETS

9.01 GENERAL

A self-contained meter socket will be used for single-phase and 3-phase electric service not exceeding 320 amperes at service voltages less than 600 volts. Meter sockets shall be of the ring-less type and conform to Section 9.04 METER SOCKET SPECIFICATIONS. Meter sockets that are part of a pedestal, multi-metered equipment, or attached to or an integral part of Member-owned service equipment shall be approved by the Cooperative prior to purchase and installation by the Member.

A self-contained meter socket shall be an outdoor-type, weatherproof construction, Underwriters Laboratories (UL) listed, and suitable for overhead or underground installation (depending on installation type) and plug-in type meter. The enclosure shall be a minimum of 16-gauge galvanized or zinc coated steel or 14-gauge aluminum with painted finish. Provision shall be made for sealing.

Meter sockets shall be securely mounted in a true vertical position on a wall or other support with a minimum of four (4) fasteners. For non-masonry structures, meter sockets shall be secured to bracing installed between exterior wall studs with 1/4" lag screws (or No. 12 sheet metal screws) embedded 1-1/2" into the wood. Where secured to brick or other masonry, tapcon or 1/4" lag screws (or No. 12 sheet metal screws) with lead anchor shields embedded 1-1/2" into the masonry shall be used. For manufactured homes (HUD approved) mounted on a permanent foundation, meter sockets shall be mounted to the exterior wall studs using the center hole positions in the socket. Meter sockets and service conduits shall not be recessed into the wall. Unmetered service entrance cables or service entrance conduits on buildings, poles or structures shall not be concealed or recessed. All cable or conduit connections on the top of the meter socket shall be rain tight.

9.02 MEMBER-FURNISHED METER SOCKETS

The Member will furnish meter sockets for the following: (See Section 9.04 for meter socket specifications).

- (a) All self-contained sockets for 100, 200 and 320 ampere, single-phase, 120/240 volt service. Also, all self-contained sockets for 100 and 200 ampere, single-phase, network, 120/208 volt service, only where 120/208 volt is available.
- (b) All self-contained sockets for 200 and 320 ampere, 3-phase, 4-wire, 240/120 volt delta, 208/120 volt wye and 480/277 volt wye services.
- (c) All 2, 4 or 6 position multi-gang meter sockets, factory assembled multi-meter centers, mobile home pedestals and other special locations requiring 120/240 volt single-phase, 3-wire service.

9.03 METER SOCKET REPAIRS/REPLACEMENTS

Members are responsible for the maintenance and replacement of their meter sockets, except those installed by Cooperative. In the event of a failure, damage or the replacement of the socket due to rewiring, the Member shall engage an electrical contractor to have this work performed. **Cooperative must be notified for disconnection and reconnection of service.**

Note: Cooperative may disconnect a faulty service for safety issues without prior notice.

9.04 METER SOCKET SPECIFICATIONS

Single-phase, 3-wire 120/240 volt meter sockets

General: 4-terminal, ring-less, UL label, socket suitable for plug-in meter. For 120/208 volt, meter sockets require a fifth terminal (jaw) in the 9 o'clock position. Requirements for approximate physical dimensions do not apply to multi-position sockets. Number of concentric knockouts may be increased on multi-position sockets.

100 Ampere Continuous (Overhead Service)

- (1) Line and load lugs: lay-in for #2 AL or CU.
- (2) Neutral: double lay-in for #2 AL or CU.
- (3) By-pass: horn-type
- (4) Approximate physical dimensions: 8.0"W X 10.5"H X 3.5"D minimum.
- (5) Raised hub opening in the top with provisions for interchangeable gasket-less conduit hubs or closure plate.

200 Ampere Continuous (Overhead Service)

- (1) Line and load lugs: lay-in for up to 350kcmil AL or CU.
- (2) Neutral: double lay-in for up to 350kcmil AL or CU.
- (3) By-pass: horn-type.
- (4) Approximate physical dimensions: 11.0"W X 14.0"H X 4.5"D minimum.
- (5) Raised hub opening in the top with provisions for interchangeable gasket-less conduit hubs or closure plate.

200 Ampere Continuous (Underground Service)

- (1) Line and load lugs: lay-in for up to 350kcmil AL or CU. Line terminals to be offset (bussed) to side. Left or right hand feed as required
- (2) Neutral: double lay-in for up to 350kcmil AL or CU offset (bussed) to side.
- (3) By-pass: horn-type.
- (4) Approximate physical dimensions: 13"W X 15.5"H X 5"D minimum.
- (5) Knockouts: two sets of concentric knockouts in bottom plate for 3" conduit.

320 Ampere Continuous (Overhead/Underground Service)

- (1) Line and load: 3/8" stud with belleville washer and nut to accommodate AL/CU terminal lugs. Line terminals to be offset (bussed) to side.
- (2) Neutral: two 3/8" studs, same as line and load.
- (3) By-pass: lever arm by-pass with jaw tension release.
- (4) Approximate physical dimensions 15.0"W X 29"H X 5.0"D minimum.
- (5) Knockouts: two sets of concentric knockouts in bottom plate for 3" conduit.
- (6) Raised hub opening in the top with provisions for interchangeable gasket-less conduit hubs or closure plate.
- (7) Socket shall be able to accept either a 200 or 320 ampere meter.

Three-phase, 4-wire, 240/120 volt delta, 208/120 volt wye and 480/277 volt wye meter sockets

General: 7-terminal, ring-less, UL label, socket suitable for plug-in meter. Meter socket shall have a transparent, crack resistant safety shield to provide protection from shorts and shock. Requirements for approximate physical dimensions do not apply to multi-position sockets. Number of concentric knockouts may be increased on multi-position sockets.

200 Ampere Continuous (Overhead Service)

- (1) Line and load lugs: lay-in for up to 350kcmil AL or CU.
- (2) Neutral: double lay-in for up to 350kcmil AL or CU.
- (3) By-pass: lever arm by-pass with jaw tension release.
- (4) Raised hub opening in the top with provisions for interchangeable gasket-less 3" conduit hubs or closure plate.
- (5) Approximate physical dimensions: 12.0"W X 19.0"H X 5.0"D minimum.
- (6) Knockouts: two sets of concentric knockouts in bottom plate for 3" conduit.

320 Ampere Continuous (Overhead/Underground)

- (1) Line and load: 3/8" stud with belleville washer and nut to accommodate AL/CU terminal lugs. Line terminals to be offset (bussed) to side.
- (2) Neutral: two 3/8" studs, same as line and load.
- (3) By-pass: lever arm by-pass with jaw tension release.
- (4) Approximate physical dimensions 18.0"W X 33.0"H X 6.0"D minimum.
- (5) Knockouts: two sets of concentric knockouts in bottom plate for 4" conduit.
- (6) Raised hub opening in the top with provisions for interchangeable gasket-less conduit hubs or closure plate.
- (7) Socket shall be able to accept either a 200 or 320 ampere meter.

Appendices:

Service and Meter Installation
Specification Drawings

Typical Overhead Service Installations 600 volts or Less

FIG. 1

TYPICAL SERVICE DROP CLEARANCE MINIMUMS FOR SERVICES UNDER 600 VOLTS

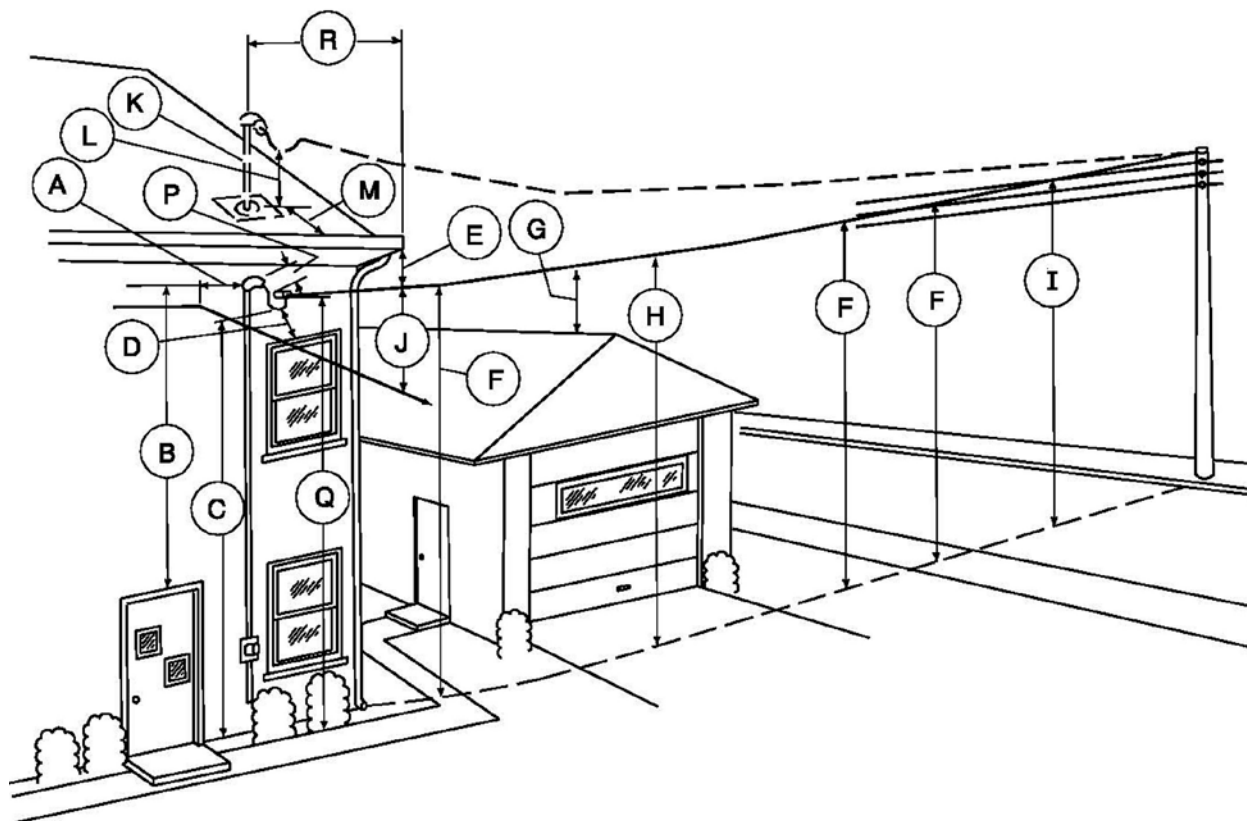

MINIMUM CLEARANCE

A	Telephone service at point of attachment	12"
B	Doors, porches, fire escapes and similar locations	3'
C	Lowest point of drip loop: Multiplex Open wire to 300V to ground	10'
		12'
D	Windows: Beside and below Above window	3'
		1'
E	Gutters and downspouts	3"
F	Sidewalks and finished grade: Multiplex Open wire to 300V to ground	12'
		12.5'
G	Refer to Section 4.08 and 5.02, for conductors not attached to but crossing over buildings	--
H	Residential driveways	16'
I	Public street, alley, public parking lot and areas subject to truck traffic	18'
J	Telephone service drop at crossing	2'
K	Optional method by use of mast. Conduit coupling must be located near meter socket. Only power service drop conductors shall be attached to the mast.	
L	Overhanging roof: if service overhang (R) 6 feet or less and "M" is 4 feet or less If service overhanging (R) greater than 6 feet, vertical clearance above roof for the remainder of horizontal distance.	18"
		3'
M	Distance from service mast to edge of roof (see dimension "L")	--
P	Point of attachment shall not be higher than the weatherhead	--
Q	Service drop attachment	12'
R	Service overhang of roof (see dimensions "L")	--

FIG. 2

TYPICAL GROUNDING DETAILS

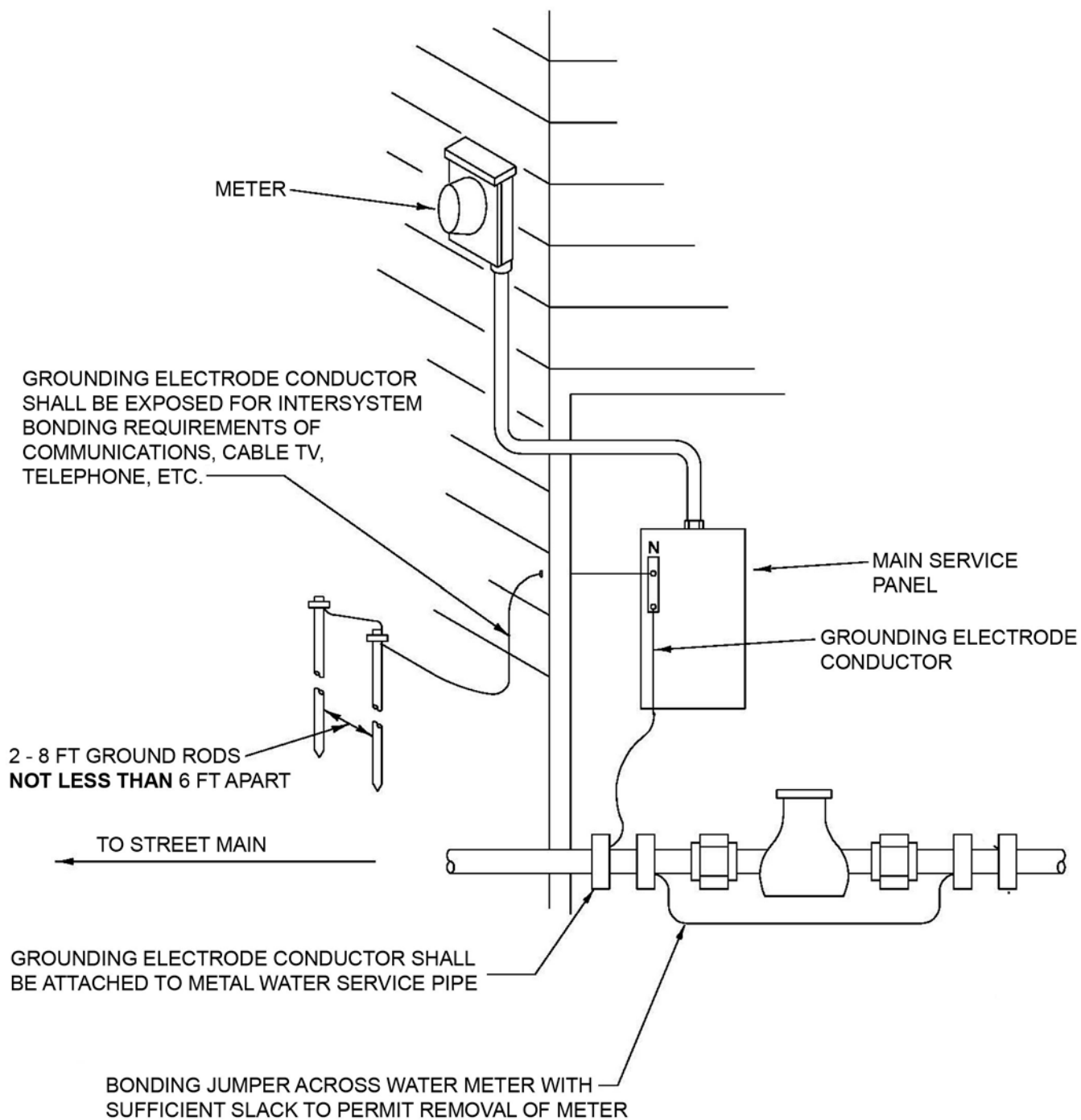
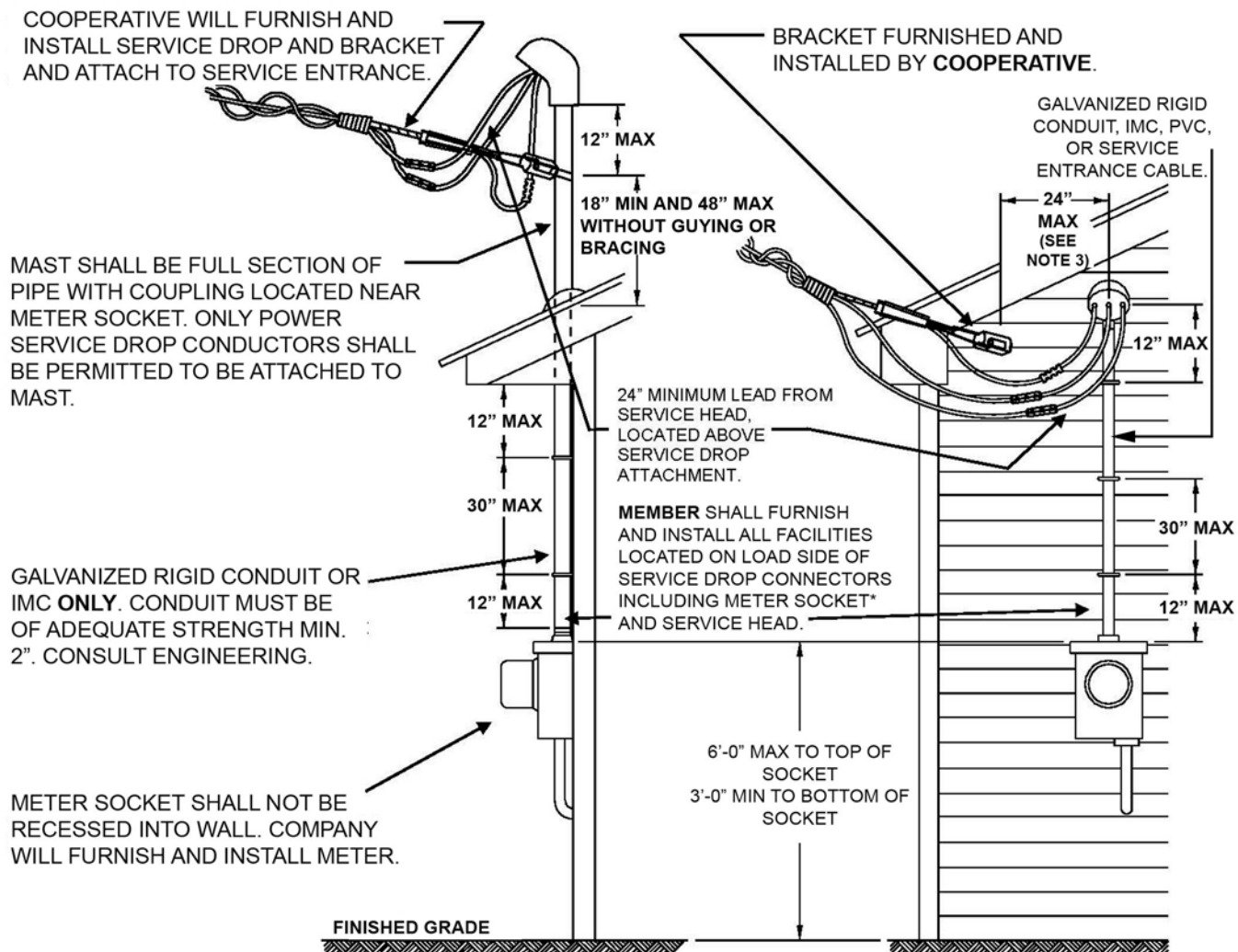

FIG. 3

TYPICAL 320 AMP OR LESS OVERHEAD SERVICE INSTALLATION



NOTES:

1. SEE FIGURE 1 FOR MINIMUM GROUND CLEARANCE.
2. SEE FIGURE 2 FOR GROUNDING REQUIREMENTS.
3. **MEMBER** SHALL CONSULT COOPERATIVE FOR POINT OF ATTACHMENT OF SERVICE DROP AND METER LOCATION. IF COOPERATIVE AGREES TO ALLOW **MEMBER** TO INSTALL BRACKET ABOVE SERVICE HEAD, BRACKET SHALL BE LOCATED NO MORE THAN 24 INCHES FROM SERVICE HEAD.
4. **INHIBITOR COMPOUND** SHALL BE USED ON ALL ALUMINUM WIRE TERMINATIONS.
5. ALL **MEMBER** WORK SHALL BE COMPLETE AND INSPECTIONS OBTAINED (SEE SECTION 4.06) BEFORE COOPERATIVE WILL PROVIDE SERVICE.
6. FOR METER SOCKET SPECIFICATIONS AND MOUNTING, SEE SECTION 9.

FIG. 4

TYPICAL TEMPORARY OVERHEAD SERVICE SUPPORT

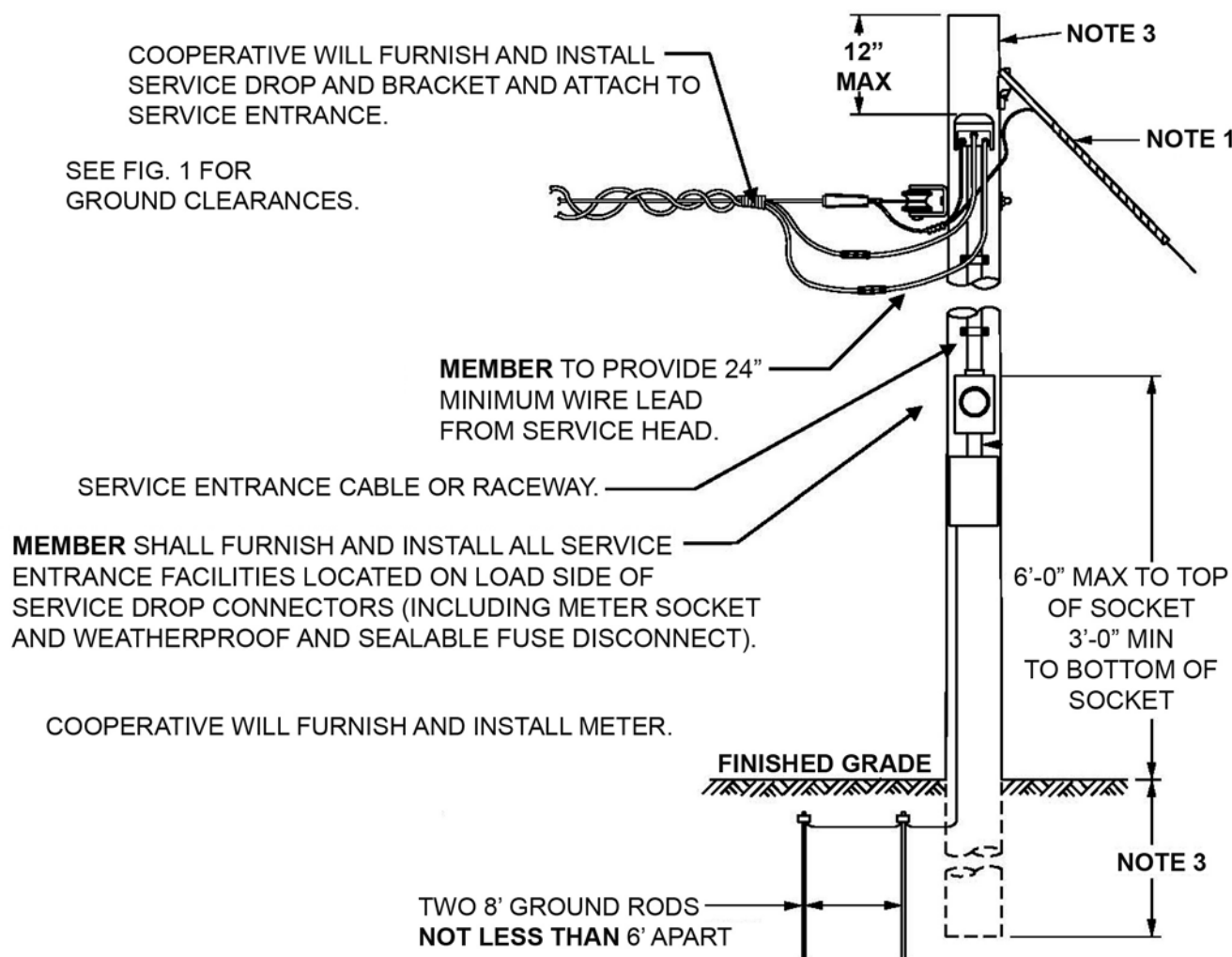

NOTES:

1. **MEMBER SHALL CONSULT WITH COOPERATIVE FOR LOCATION OF TEMPORARY SERVICE POLE. SUCH POLE SHALL BE LOCATED NOT LESS THAN 10' OR MORE THAN 50' FROM COOPERATIVE'S TRANSFORMER SECONDARY, UNLESS OTHERWISE APPROVED BY COOPERATIVE. MEMBER WILL BE REQUIRED TO MAKE TEMPORARY POLE STRUCTURALLY SOUND TO SUPPORT SERVICE DROP. MEMBER SHALL PAY APPLICABLE CHARGES.**
2. **MEMBER MUST ADHERE TO CURRENT COOPERATIVE SPECIFICATIONS. MEMBER MAY USE A COOPERATIVE TEMPORARY SERVICE FOR A FEE.**
3. **ALL MEMBER WORK SHALL BE COMPLETED AND INSPECTIONS OBTAINED (SEE SECTION 4.06) BEFORE COOPERATIVE WILL PROVIDE SERVICE. HEIGHT MUST BE SUFFICIENT TO MEET NESC/NEC CODE REQUIREMENTS.**
4. **INHIBITOR COMPOUND SHALL BE USED ON ALL ALUMINUM WIRE TERMINATIONS.**
5. **COMPLETE MEMBER POLE INSTALLATION SUBJECT TO COOPERATIVE APPROVAL PRIOR TO CONNECTION.**

TYPICAL OVERHEAD SERVICE FOR INDIVIDUALLY LOCATED MOBILE HOMES

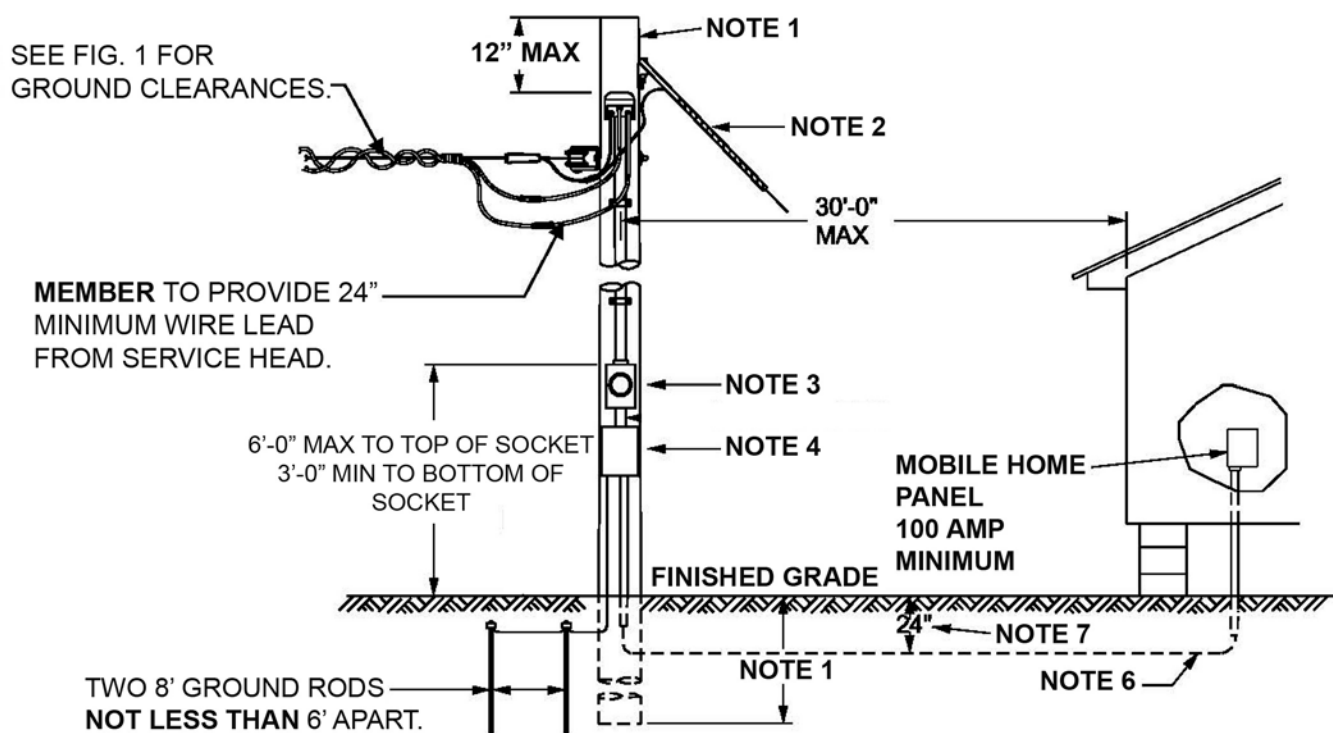

NOTES:

1. ALL METER POLES SHALL BE PROVIDED AND INSTALLED BY THE COOPERATIVE. MEMBER WILL BE RESPONSIBLE FOR ANY AND ALL COSTS.
2. IF SERVICE DROP EXCEEDS 100' OR PROPER POLE SETTING DEPTH CANNOT BE OBTAINED, **MEMBER** SHALL PROVIDE AN AREA FOR PROPER GUYING. COOPERATIVE WILL BOND GUY TO SERVICE NEUTRAL.
3. **MEMBER** SHALL FURNISH AND INSTALL ALL SERVICE ENTRANCE FACILITIES LOCATED ON THE LOAD SIDE OF SERVICE DROP CONNECTORS. COOPERATIVE WILL FURNISH AND INSTALL METER.
4. THE SERVICE ENTRANCE SHALL BE A MINIMUM 100 AMP. WITH MAIN DISCONNECT AND MEANS FOR CONNECTING AN ACCESSORY BUILDING OR ADDITIONAL ELECTRICAL EQUIPMENT LOCATED OUTSIDE MOBILE HOME. SERVICE DISCONNECT SHALL BE LOCATED WITHIN SIGHT OF AND WITHIN 30 FEET OF THE MOBILE HOME.
5. ALL **MEMBER** WORK SHALL BE COMPLETED AND INSPECTIONS OBTAINED (SEE SECTION 4.06) BEFORE COOPERATIVE WILL PROVIDE SERVICE.
6. FEEDER: 4-WIRE, USE PERMANENT WIRING IF OVER 50 AMP.
7. BURIAL DEPTH MAY BE REDUCED TO 18" IF FEEDER IS IN SPECIFIED CONDUIT.
8. **INHIBITOR COMPOUND** SHALL BE USED ON ALL ALUMINUM WIRE TERMINATIONS.
9. ANTENNAS, SATELLITE DISHES, OR AERIALS SHALL NOT BE ATTACHED TO ANY POLE USED FOR SUPPLYING ELECTRIC SERVICE TO **MEMBERS**.

GENERAL OVERHEAD POLE MOUNTED SELF – CONTAINED SERVICE

SINGLE OR THREE PHASE POLE MOUNTED SERVICE EQUIPMENT/MAIN DISCONNECT (EXCLUDES MOBILE HOME AND CENTRAL DISTRIBUTION SERVICE)

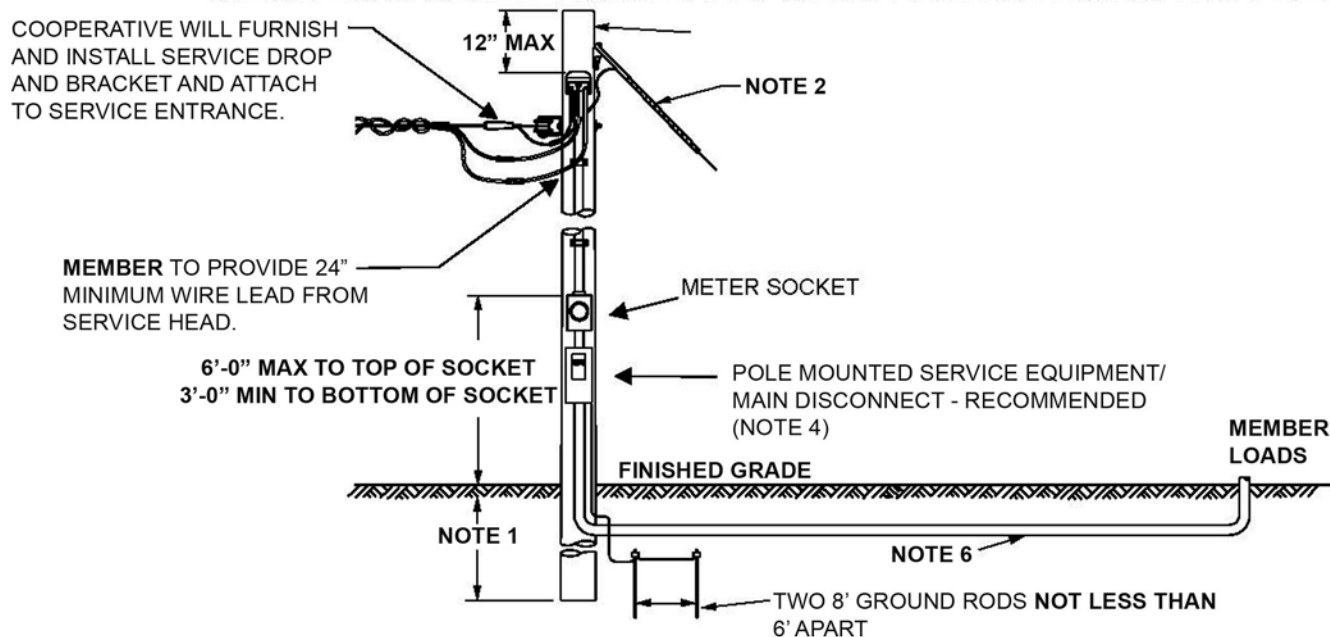

NOTES:

1. ALL METER POLES SHALL BE PROVIDED AND INSTALLED BY THE COOPERATIVE. **MEMBER** WILL BE RESPONSIBLE FOR ANY AND ALL COSTS.
2. **MEMBER** SHALL PROVIDE AREA FOR PROPER GUYING.
3. **MEMBER** SHALL FURNISH AND INSTALL ALL SERVICE ENTRANCE FACILITIES LOCATED ON THE LOAD SIDE OF SERVICE DROP CONNECTORS (INCLUDING METER SOCKET). COOPERATIVE WILL FURNISH AND INSTALL METER.
4. THE SERVICE ENTRANCE SHALL BE MINIMUM 100 AMP WITH A MAIN DISCONNECT MEANS RECOMMENDED AND LABELED "SUITABLE FOR USE AS SERVICE EQUIPMENT".
5. ALL **MEMBER** WORK SHALL BE COMPLETED AND INSPECTIONS OBTAINED (SEE SECTION 4.06) BEFORE COOPERATIVE WILL PROVIDE SERVICE.
6. MINIMUM BURIAL DEPTH OF 24". BURIAL DEPTH MAY BE REDUCED TO 18" IF SERVICE CONDUCTORS ARE IN SPECIFIED CONDUIT.
7. **INHIBITOR COMPOUND** SHALL BE USED ON ALL ALUMINUM WIRE TERMINATIONS.
8. ANTENNAS, SATELLITE DISHES, OR AERIALS SHALL NOT BE ATTACHED TO ANY POLE USED FOR SUPPLYING ELECTRIC SERVICE TO **MEMBERS**.

POLE MOUNTED SELF-CONTAINED METER NOT EXCEEDING 320 AMPS, MEMBER CENTRAL DISTRIBUTION SERVICE OR FARM METER POLE

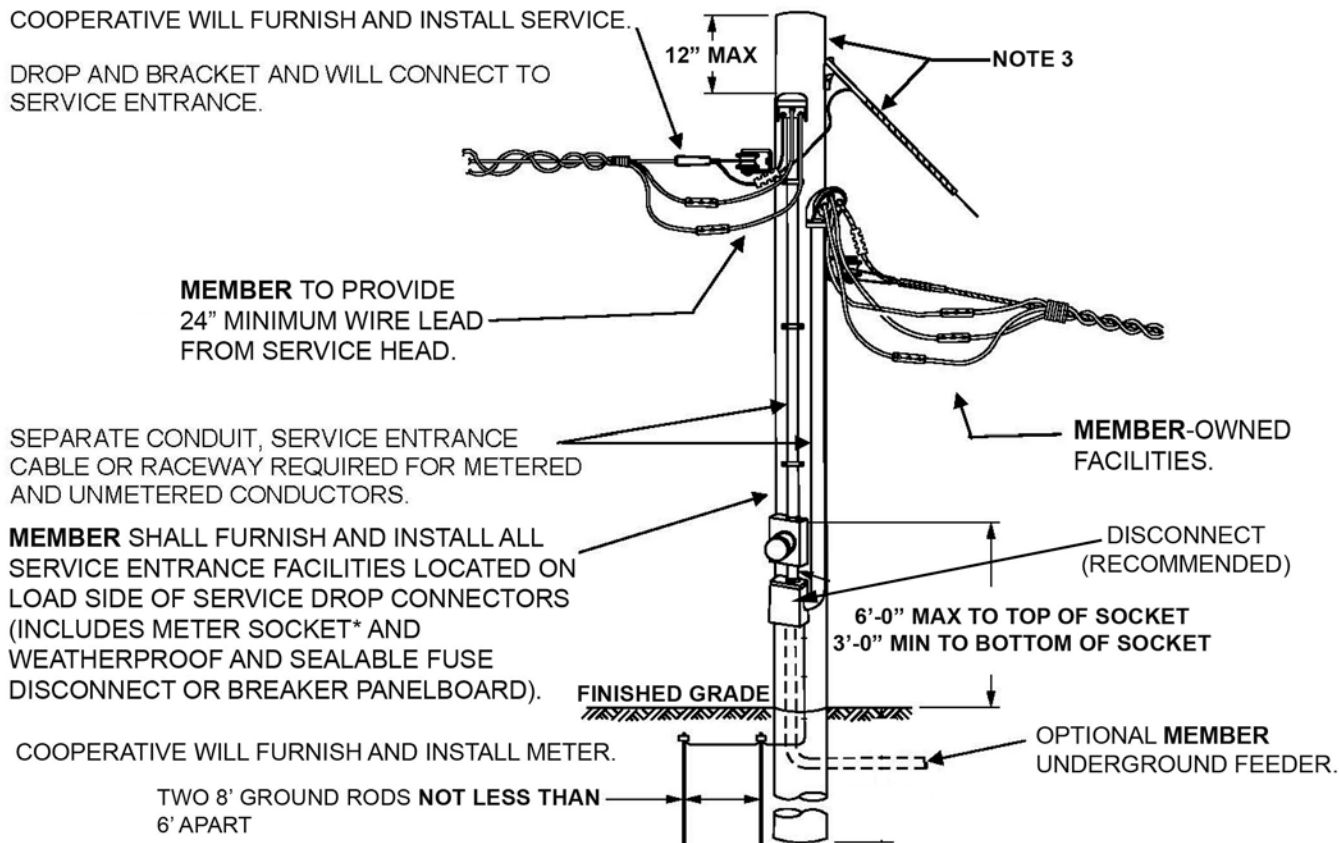

NOTES:

1. **MEMBER** SHALL CONSULT WITH COOPERATIVE BEFORE INSTALLING CENTRAL DISTRIBUTION SERVICE.
2. ALL **MEMBER** WORK SHALL BE COMPLETED AND INSPECTIONS OBTAINED (SEE SECTION 4.06) BEFORE COOPERATIVE WILL PROVIDE SERVICE.
3. **MEMBER** SHALL PROVIDE AREA FOR PROPER GUYING. ALL METER POLES SHALL BE PROVIDED AND INSTALLED BY THE COOPERATIVE. MEMBER WILL BE RESPONSIBLE FOR ANY AND ALL COSTS.
4. ANTENNAS OR AERIALS SHALL NOT BE ATTACHED TO ANY POLE USED FOR SUPPLY OF ELECTRIC SERVICE TO **MEMBER**.
5. **INHIBITOR COMPOUND** SHALL BE USED ON ALL ALUMINUM WIRE TERMINATIONS.
6. WHEN LOAD EXCEEDS 320 AMPS, CONTACT THE COOPERATIVE.

FIG. 7b

POLE MOUNTED SELF-CONTAINED METER NOT EXCEEDING 320 AMPS, MEMBER CENTRAL DISTRIBUTION SERVICE WITH STAND-BY GENERATOR FACILITIES OR FARM METER POLE

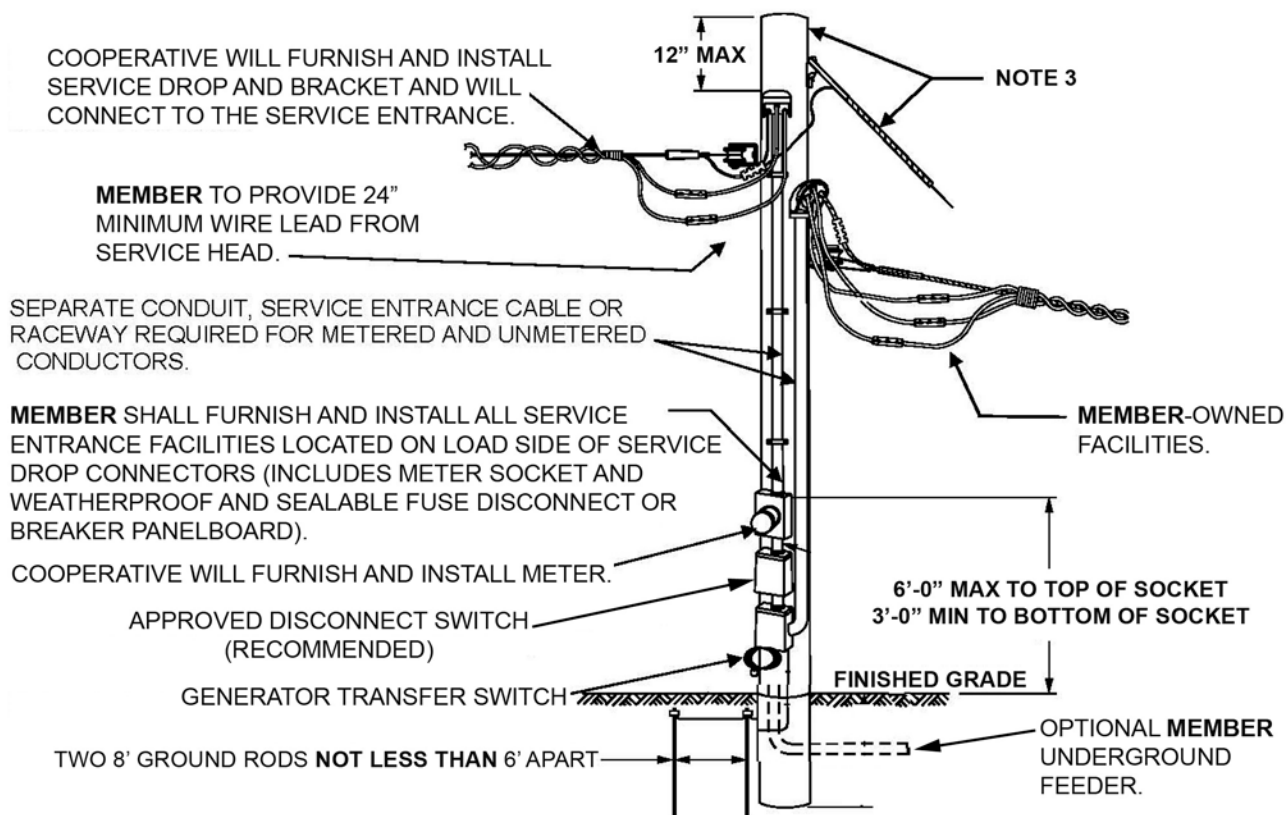

NOTES:

1. **MEMBER SHALL CONSULT WITH COOPERATIVE** BEFORE INSTALLING CENTRAL DISTRIBUTION SERVICE.
2. ALL EMERGENCY STAND-BY GENERATOR FACILITIES SHALL BE INSTALLED IN ACCORDANCE WITH APPLICABLE CODES AND BE SUBJECT TO COOPERATIVE APPROVAL.
3. **MEMBER** SHALL PROVIDE AREA FOR PROPER GUYING. ALL METER POLES SHALL BE PROVIDED AND INSTALLED BY THE COOPERATIVE. MEMBER WILL BE RESPONSIBLE FOR ANY AND ALL COSTS.
4. ANTENNAS OR AERIALS SHALL NOT BE ATTACHED TO ANY POLE USED FOR SUPPLY OF ELECTRIC SERVICE TO **MEMBER**.
5. **INHIBITOR COMPOUND** SHALL BE USED ON ALL ALUMINUM WIRE TERMINATIONS.
6. ALL **MEMBER** WORK SHALL BE COMPLETED AND INSPECTIONS OBTAINED (SEE SECTION 4.06) BEFORE COOPERATIVE WILL PROVIDE SERVICE.
7. WHEN LOAD EXCEEDS 320 AMPS, SEE FIGURE 11.

FIG. 8

STAND-BY GENERATOR FOR 120-240 VOLT SINGLE PHASE SERVICE (MEMBER OWNED)

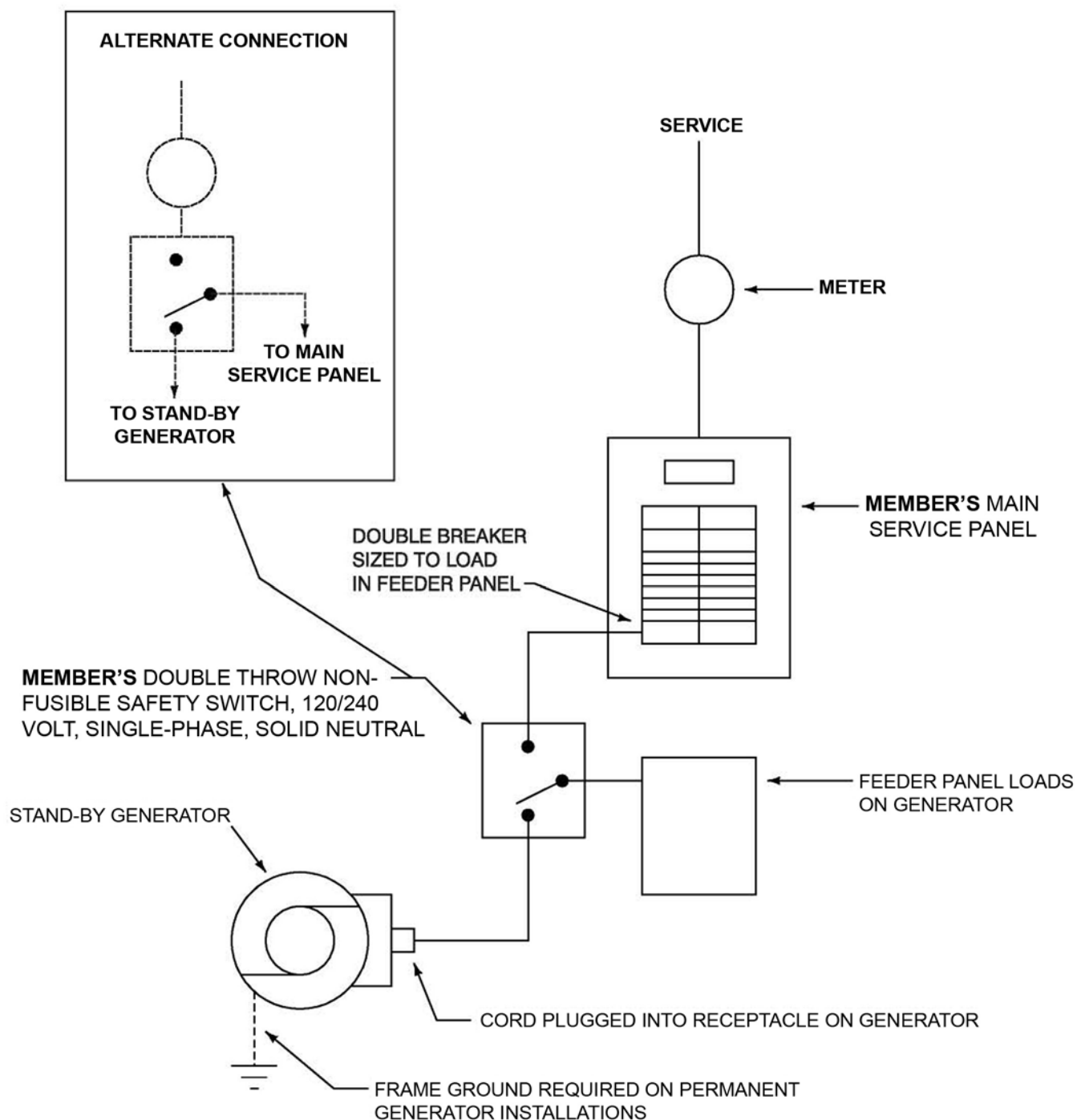

This is for illustrative purposes only, refer to policy C-30 (www.reaenergy.com) or call REA Energy Services, Inc. for expert sales and installation.

TYPICAL OVERHEAD SERVICE INSTALLATION BUILDING ATTACHMENT 3-PHASE, 4-WIRE SERVICE

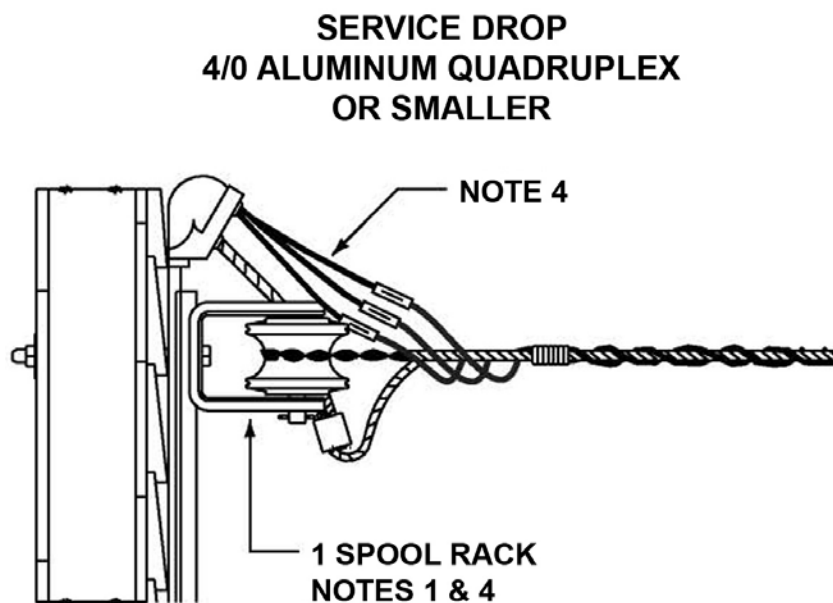

NOTES:

1. COOPERATIVE SHALL FURNISH AND INSTALL CLEVIS ATTACHMENTS UNLESS CIRCUMSTANCES WARRANT THE MEMBER TO INSTALL.
2. CONSULT COOPERATIVE IF CLEVIS IS TO BE MOUNTED ON BRICK, CONCRETE OR TILE WALL.
3. COOPERATIVE TERMINATES SERVICE DROP ON CLEVIS AT A SINGLE POINT TO BE DETERMINED BY THE COOPERATIVE.
4. **MEMBER** SHALL FURNISH AND INSTALL SERVICE ENTRANCE CONDUCTORS – 24" MINIMUM LEAD FROM SERVICE HEAD. IF COOPERATIVE AGREES TO ALLOW **MEMBER** TO INSTALL BRACKET(S) ABOVE SERVICE HEAD, FURTHEREST BRACKET SHALL BE LOCATED NO MORE THAN 24 INCHES FROM SERVICE HEAD.
5. FOR SERVICES LARGER THAN 4/0 ALUMINUM CONTACT THE COOPERATIVE.

CONNECTING TYPICAL MULTIPLE SERVICES

CONSULT COOPERATIVE FOR DETAIL BEFORE INSTALLATION

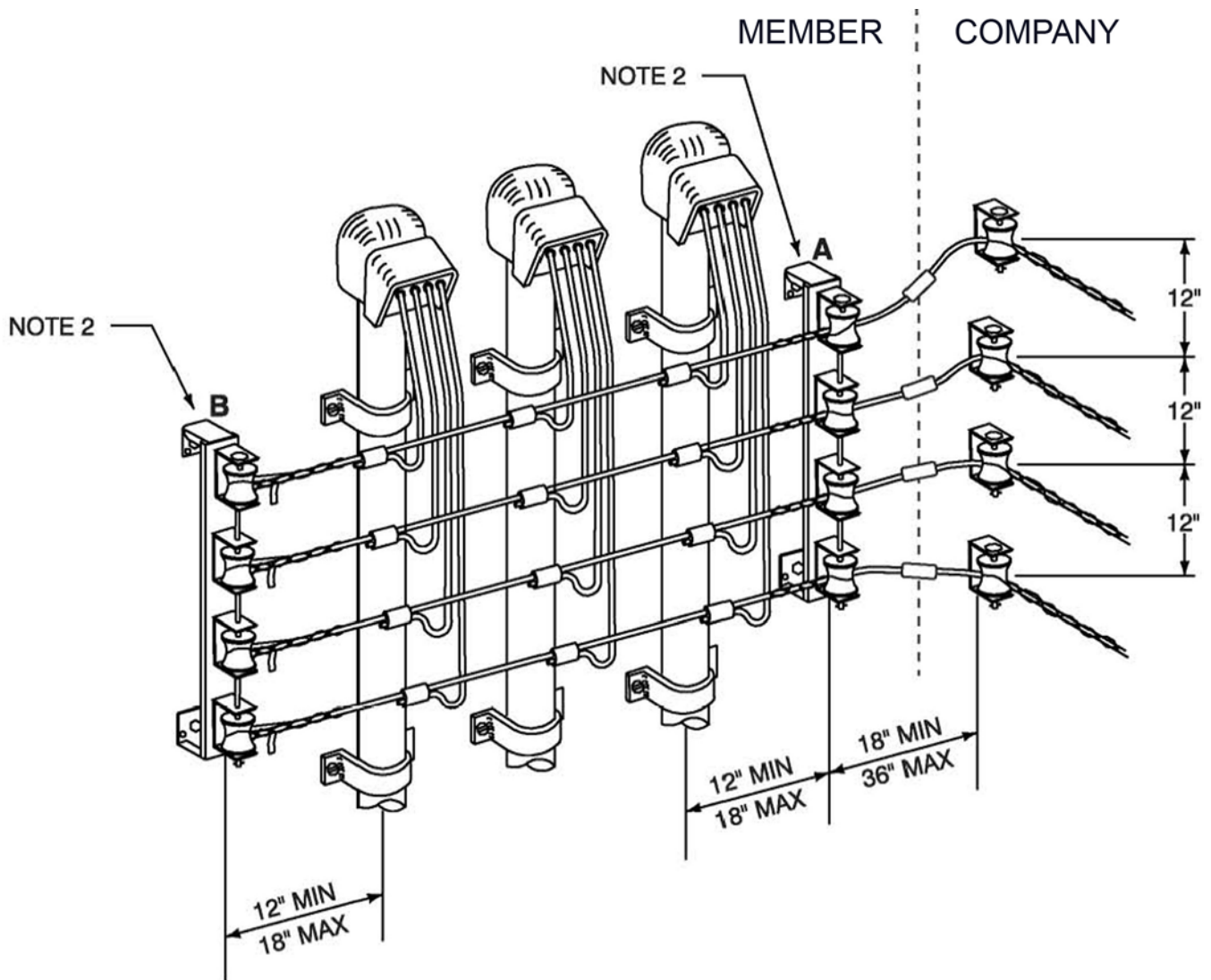

NOTES:

1. COOPERATIVE TERMINATES SERVICE DROP ON ONE-POINT RACKS AT A SINGLE POINT AGREED ON BY **MEMBER** AND COOPERATIVE. COOPERATIVE INSTALLS BUS WIRING (A TO B) WHEN SERVICE TO MORE THAN ONE MEMBER IS REQUIRED.
2. **MEMBER** FURNISHES AND INSTALLS MOUNTING BRACKETS AND INSULATORS. INDIVIDUAL ONE-POINT RACKS MAY BE SUBSTITUTED FOR MULTIPLE SPOOL BRACKETS.
3. TYPICAL POLYPHASE INSTALLATION SHOWN ABOVE. THIS METHOD SHALL ALSO BE USED FOR SINGLE-PHASE INSTALLATIONS.
4. MEMBER NEEDS TO CONSULT WITH COOPERATIVE BEFORE COMMENCEMENT OF WORK.

POLE MOUNTED TRANSFORMER-RATED METERING

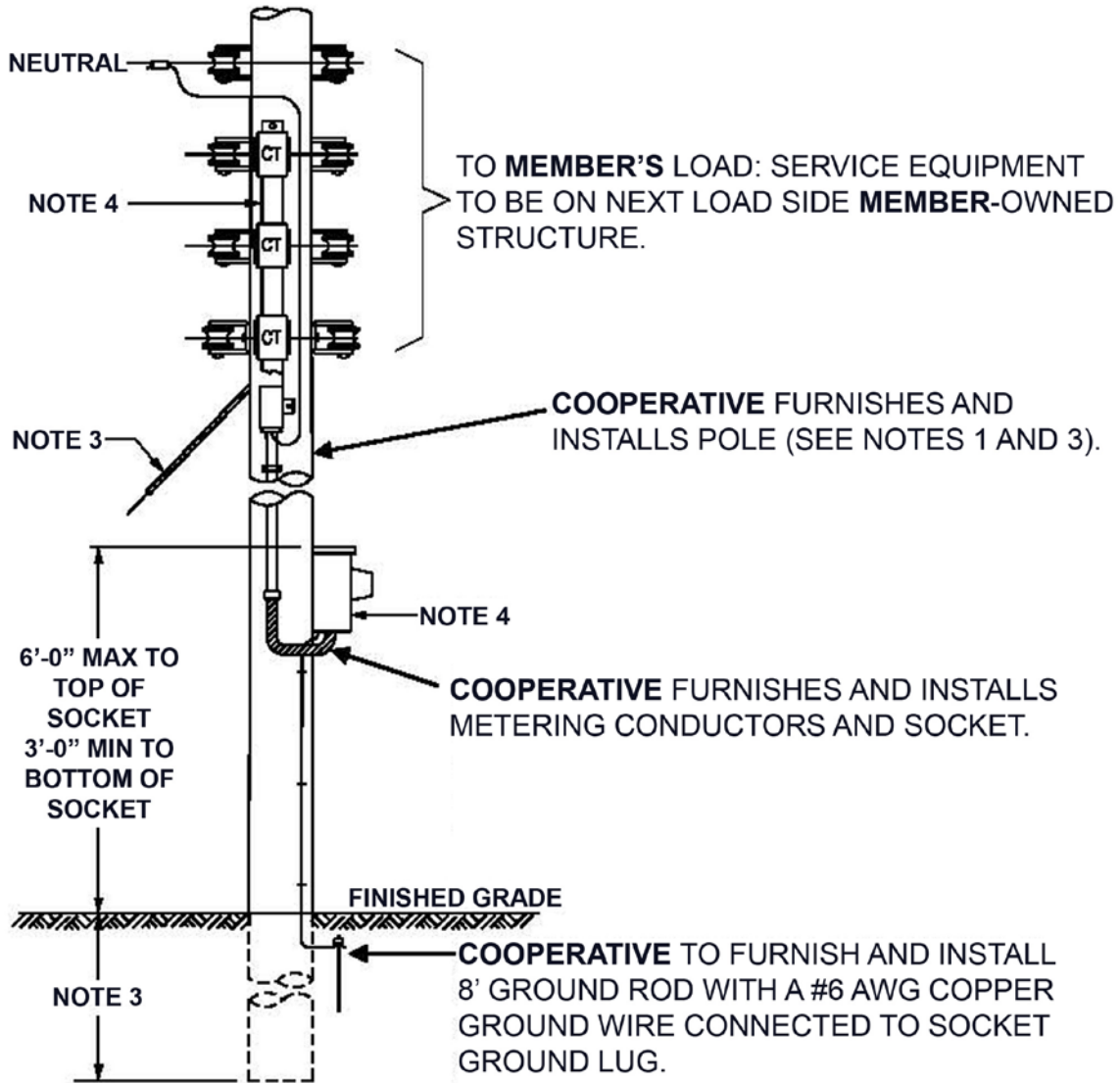

NOTES:

1. **MEMBER SHALL CONSULT COOPERATIVE** FOR LOCATION OF POLE.
2. ALL **MEMBER** WORK SHALL BE COMPLETED AND INSPECTIONS OBTAINED (SEE SECTION 4.06) BEFORE COOPERATIVE WILL PROVIDE SERVICE.
3. **MEMBER** SHALL PROVIDE AREA FOR PROPER GUYING. ALL METER POLES SHALL BE PROVIDED AND INSTALLED BY THE COOPERATIVE. MEMBER WILL BE RESPONSIBLE FOR ANY AND ALL COSTS.
4. METERING TRANSFORMER PACKAGE AND METER SOCKET SUPPLIED BY COOPERATIVE AND INSTALLED BY THE **COOPERATIVE**. NUMBER OF CURRENT AND VOLTAGE TRANSFORMERS WILL VARY WITH SERVICE TYPE.

Typical Underground Service
Installations
600 volts or Less

TYPICAL 320 AMP OR LESS UNDERGROUND SERVICE INSTALLATION

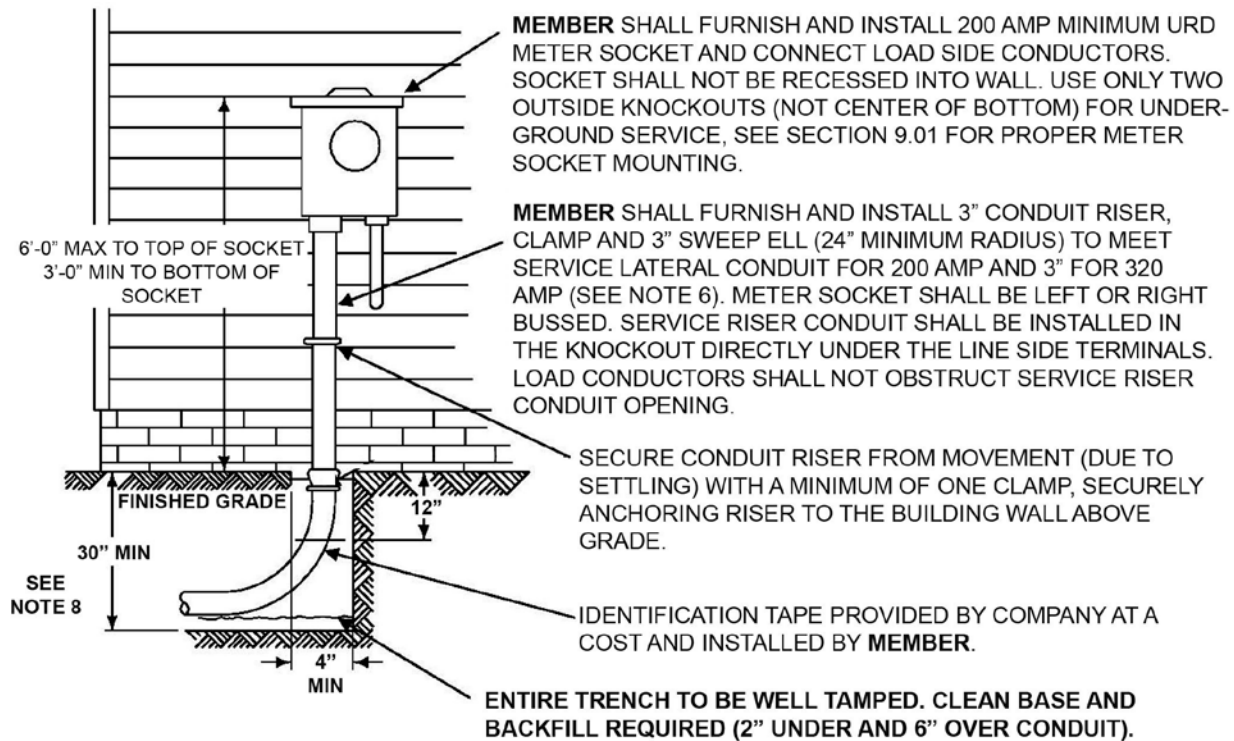

NOTES:

- MEMBER SHALL CONTACT COOPERATIVE FOR METER LOCATION. MEMBER TO TRENCH AND BACKFILL; FURNISH AND INSTALL CONDUIT WITH AN APPROVED PULL ROPE FOR COOPERATIVE SERVICE LATERAL CONDUCTORS. TRENCH IS TO BE EXCAVATED IN LOCATION INDICATED BY COOPERATIVE AND GRADED TO WITHIN 6" OF FINISHED GRADE. SEE FIGURES 28 AND 29 FOR TYPICAL TRENCHING DETAILS.**
- ALL **MEMBER** WORK SHALL BE COMPLETED AND INSPECTIONS OBTAINED (SEE SECTION 4.06) BEFORE COOPERATIVE WILL PROVIDE SERVICE.
- SEE FIG. 2 FOR GROUNDING REQUIREMENTS.
- SEE SECTION 9 FOR METER SOCKET SPECIFICATIONS.
- INHIBITOR COMPOUND SHALL BE USED ON ALL ALUMINUM WIRE TERMINATIONS.**
- FOR 200 AMP, CONDUIT RISER AND SWEEP ELBOW SHALL BE **3" SCHEDULE 40 PVC** OR EQUIVALENT. SERVICE LATERAL CONDUIT SHALL BE 3" DIAMETER TYPE II PVC RIGID CONDUIT SCHEDULE 40. FOR 320 AMP, CONDUIT RISER AND SWEEP ELBOW SHALL BE **3" SCHEDULE 40 PVC** OR EQUIVALENT. SERVICE LATERAL CONDUIT SHALL BE 3" DIAMETER TYPE II PVC RIGID CONDUIT SCHEDULE 40. ALL CONDUIT SHALL BE ELECTRICAL GRADE. CLAMPS SHALL BE SECURELY ANCHORED TO FRAMING TIMBER OR MASONRY. FOR 320 AMP SERVICES, CONDUIT MAY BE REQUIRED TO BE 4". CONSUMER IS RESPONSIBLE FOR PROVIDING ENOUGH CONDUIT FOR UP THE POLE, ALONG WITH SIX STRAPS AND LAGS FOR ATTACHMENT TO POLE, AND WEATHERHEAD. **(RISER IS SUPPLIED BY MEMBER FOR PRIMARY AND SECONDARY CONDUIT LARGER THAN 2-1/2" ALONG WITH SIX STRAPS AND LAGS AND WEATHERHEAD). MEMBER TO LEAVE LAST CONDUIT JOINT AND SWEEP OFF AT RISER POLE.**
- MEMBER SHALL PROVIDE 3" TYPE II PVC OR SCHEDULE 40 SWEEP ELL (24" MINIMUM RADIUS) AT TERMINAL POLE OR PAD MOUNTED TRANSFORMER.**

FIG. 21

TYPICAL 200 AMP OR LESS UNDERGROUND MOBILE HOME SERVICE FOR PARKS OR INDIVIDUALLY LOCATED HOMES

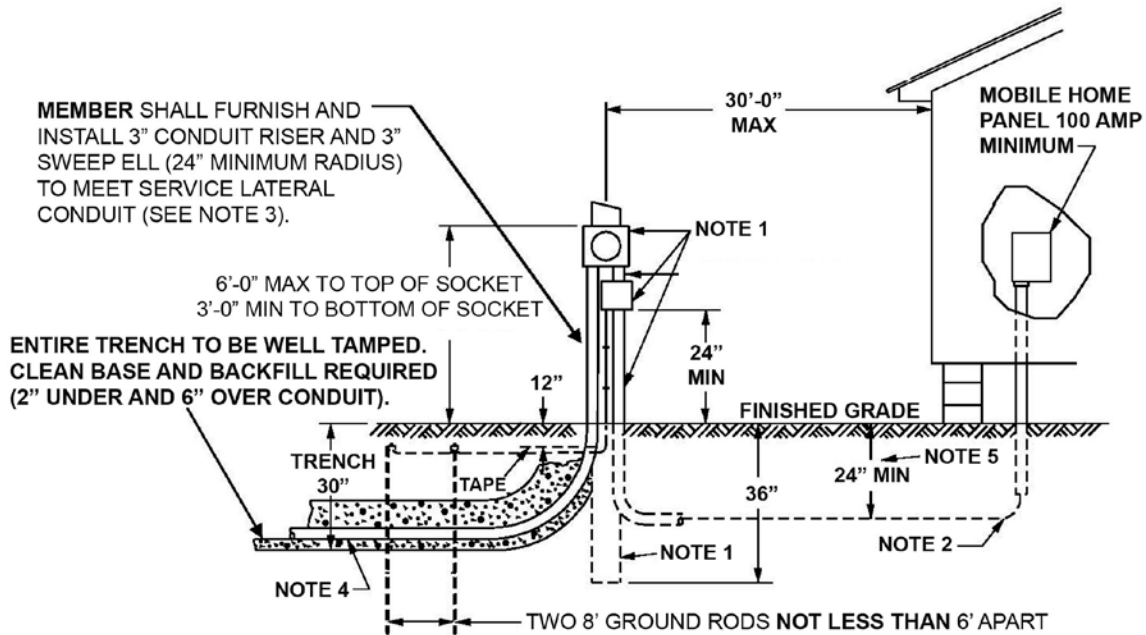

NOTES:

1. **MEMBER** SHALL FURNISH AND INSTALL 200 AMP MINIMUM UNDERGROUND METER SOCKET; 100 AMP MINIMUM MAIN DISCONNECT AND MEANS FOR CONNECTING AN ACCESSORY BUILDING OR ADDITIONAL ELECTRICAL EQUIPMENT LOCATED OUTSIDE MOBILE HOME; AND APPROPRIATE CONDUIT TYPE WHEN USED ON MINIMUM SIZE 6" X 6 X 8' PRESSURE TREATED POST. METERING PEDESTAL OR METER SOCKET/MAIN DISCONNECT COMBINATION ALSO ACCEPTABLE (SEE SECTION 6.08). SERVICE DISCONNECT SHALL BE LOCATED WITHIN SIGHT OF AND WITHIN 30 FEET OF THE MOBILE HOME.
2. **MEMBER** SHALL FURNISH AND CONNECT ALL LOAD SIDE CONDUCTORS. COOPERATIVE WILL CONNECT LINE SIDE CONDUCTORS AND INSTALL METER. **MEMBER** SHALL FURNISH AND INSTALL 4-WIRE, PERMANENT WIRING IF OVER 50 AMPS.
3. **MEMBER** SHALL FURNISH AND INSTALL CONDUIT RISER AND SWEEP ELL. CONDUIT RISER AND SWEEP ELL SHALL BE **3" SCHEDULE 40 PVC** OR EQUIVALENT. SERVICE LATERAL CONDUIT SHALL BE 3" DIAMETER TYPE II PVC RIGID CONDUIT SCHEDULE 40. ALL CONDUIT MUST BE ELECTRICAL GRADE.
4. **MEMBER** TO TRENCH AND BACKFILL; FURNISH AND INSTALL CONDUIT WITH APPROVED PULL ROPE FOR COOPERATIVE SERVICE LATERAL CONDUCTORS. TRENCH TO BE EXCAVATED IN LOCATION INDICATED BY COOPERATIVE. IDENTIFICATION TAPE PROVIDED BY COOPERATIVE FOR A FEE AND INSTALLED BY **MEMBER**. SEE FIGURES 28 AND 29 FOR TYPICAL TRENCHING DETAILS. (RISER IS SUPPLIED BY **MEMBER** FOR PRIMARY AND SECONDARY CONDUIT LARGER THAN 3" ALONG WITH SIX STRAPS AND LAGS AND WEATHERHEAD). **MEMBER** TO LEAVE LAST CONDUIT JOINT AND SWEEP OFF AT RISER POLE.
5. BURIAL DEPTH MAY BE REDUCED TO 18" IF FEEDER IS IN SPECIFIED CONDUIT.
6. **INHIBITOR COMPOUND** SHALL BE USED ON ALL ALUMINUM WIRE TERMINATIONS.
7. ALL **MEMBER** WORK SHALL BE COMPLETED AND INSPECTIONS OBTAINED (SEE SECTION 4.06) BEFORE COOPERATIVE WILL PROVIDE SERVICE.
8. **MEMBER** SHALL PROVIDE 3" TYPE II PVC OR SCHEDULE 40 SWEEP ELL (24" MINIMUM RADIUS) AT TERMINAL POLE OR PAD MOUNTED TRANSFORMER.

TEMPORARY UNDERGROUND SERVICE SUPPORT AT TRANSFORMER

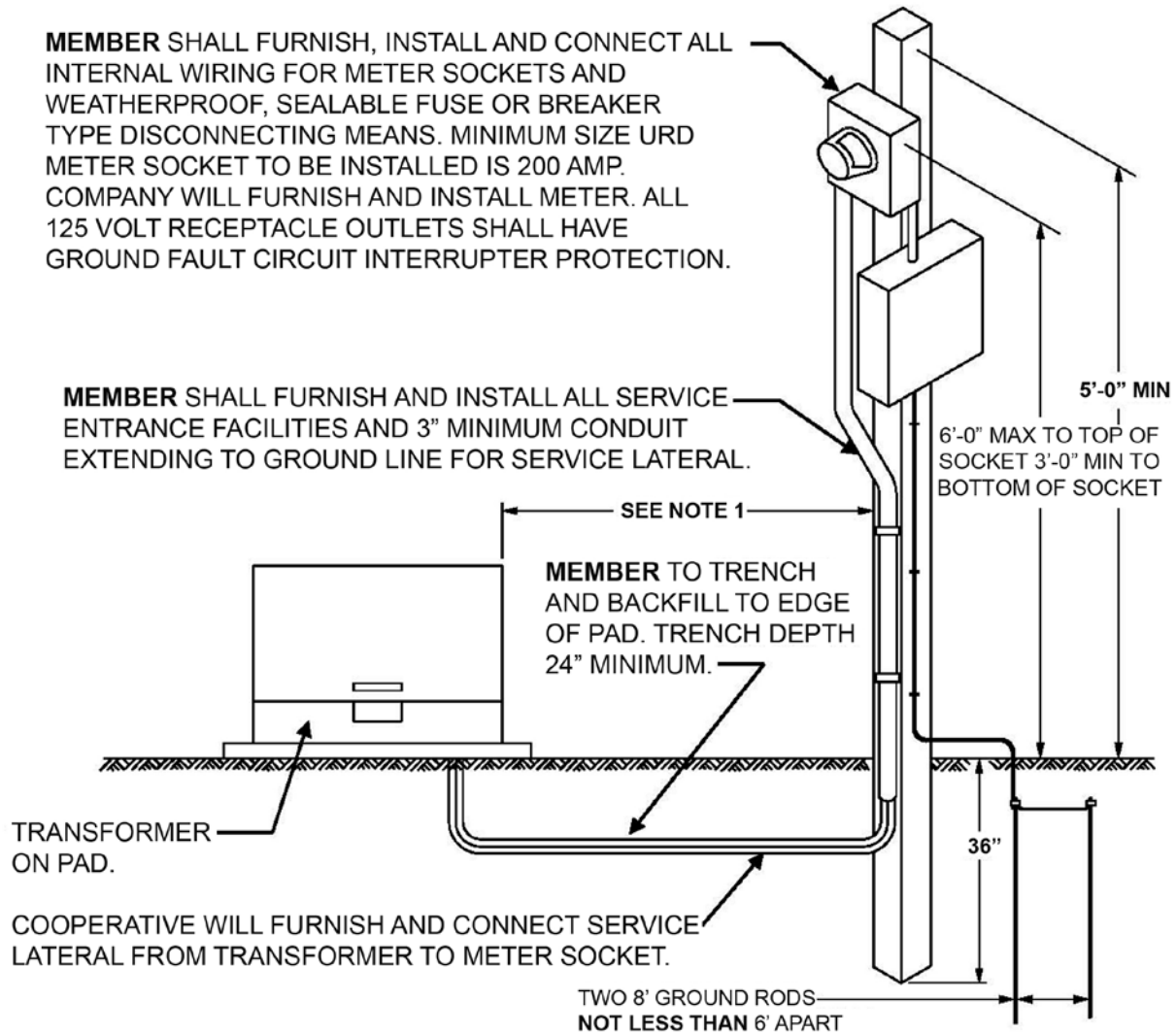

NOTES:

1. **MEMBER** SHALL CONSULT WITH COOPERATIVE FOR LOCATION OF TEMPORARY SERVICE POST OR SUPPORT. SUCH SUPPORT SHALL BE LOCATED WITHIN 5' OF COOPERATIVE'S TRANSFORMER OR SECONDARY, UNLESS OTHERWISE APPROVED BY COOPERATIVE.
2. **MEMBER** SHALL FURNISH AND INSTALL A NOMINAL 4" X 4" X 8', PRESSURE TREATED POST OR OTHER COOPERATIVE APPROVED SUPPORT. MEMBER MAY USE COOPERATIVE TEMPORARY SERVICE UPON PAYING CURRENT FEE.
3. **MEMBER** SHALL TRENCH AND BACKFILL FOR COOPERATIVE SERVICE LATERAL CONDUCTORS. TRENCH TO BE EXCAVATED IN LOCATION INDICATED BY COOPERATIVE.
4. **INHIBITOR COMPOUND** SHALL BE USED ON ALL ALUMINUM WIRE TERMINATIONS.
5. ALL **MEMBER** WORK SHALL BE COMPLETED, ARRANGEMENTS MADE FOR PAYMENT OF APPLICABLE CHARGES AND INSPECTIONS OBTAINED (SEE SECTION 4.06) BEFORE COOPERATIVE WILL PROVIDE SERVICE.

TYPICAL TRANSFORMER-RATED METERING INSTALLATION AT PAD-MOUNTED TRANSFORMER (3-PHASE, 4-WIRE SERVICE)

CONSULT COOPERATIVE FOR DETAIL BEFORE INSTALLATION

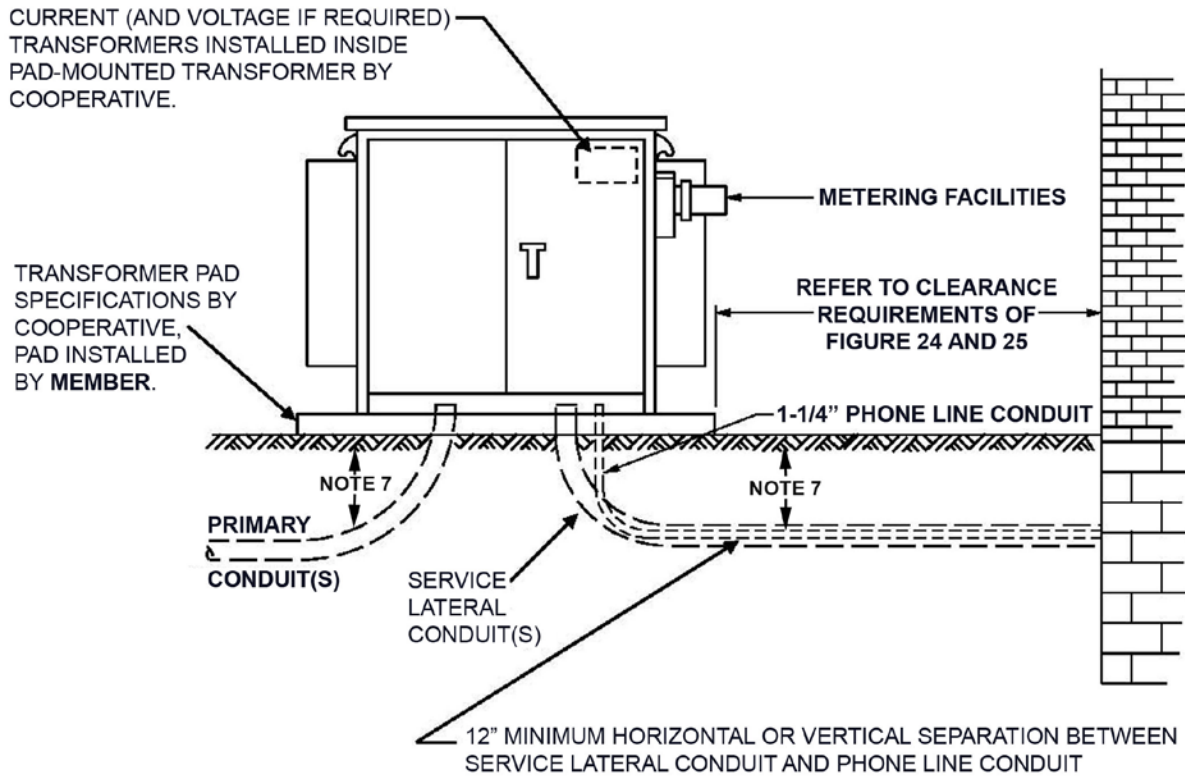

NOTES:

1. FOR METERING LOCATED AT PAD-MOUNTED TRANSFORMER, SERVICE LATERAL SHALL BE FURNISHED, INSTALLED, OWNED AND MAINTAINED BY **MEMBER** (SEE SECTION 6.03). IN ADDITION TO SERVICE LATERAL CONDUIT, **MEMBER** SHALL FURNISH AND INSTALL 1-1/4" DIAMETER CONDUIT WITH APPROVED PULL ROPE FROM SECONDARY COMPARTMENT OF PAD-MOUNTED TRANSFORMER TO LOCATION AT **MEMBER'S** BUILDING WHERE TELEPHONE LINE SERVICE CAN BE MADE AVAILABLE AT THE TELEPHONE DEMARCATION POINT (SEE SECTION 8.08). CONTACT COOPERATIVE REGARDING TELEPHONE REQUIREMENT.
2. TRENCHING AND BACKFILLING SHALL BE DONE BY THE **MEMBER**.
3. SERVICE LATERAL INSTALLED IN CONDUIT SHALL BE INSTALLED AS A-B-C-N IN EACH CONDUIT. PER NEC REQUIREMENTS. CONDUCTORS SHALL BE COLOR-CODED ACCORDING TO NEC REQUIREMENTS.
4. **MEMBER** WILL PROVIDE ALL CONNECTORS AND COOPERATIVE WILL MAKE ALL CONNECTIONS AT TRANSFORMER.
5. **MEMBER** SHALL GIVE COOPERATIVE ADEQUATE ADVANCE NOTICE AS TO NUMBER AND SIZE OF CONDUCTORS **MEMBER** WILL INSTALL.
6. BARRIERS MAY BE REQUIRED BY COOPERATIVE FOR PROTECTION OF TRANSFORMER FROM VEHICULAR DAMAGE.
7. REFER TO FIGURE 28 FOR PRIMARY AND SECONDARY CONDUIT BURIAL DEPTHS.

CLEARANCE REQUIREMENTS FROM BUILDINGS FOR PAD-MOUNTED TRANSFORMER

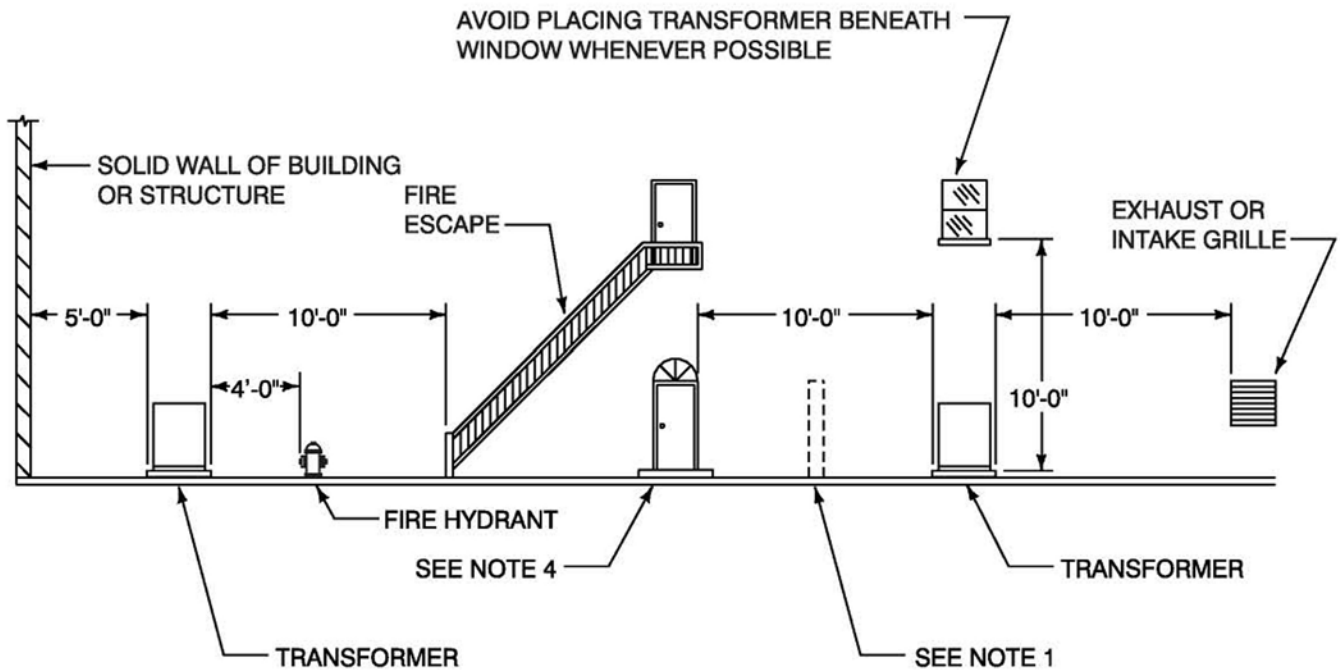

NOTES:

1. IN CASES WHERE REQUIRED DISTANCES CANNOT BE OBTAINED, FIRE RESISTANT BARRIER OF 6' MINIMUM HEIGHT SHALL BE CONSTRUCTED.
2. CERTAIN CONDITIONS MAY REQUIRE CURBING TO CONFINE OIL IN CASE OF TANK RUPTURE.
3. NO PORTION OF BUILDING OR BUILDING STRUCTURE SHALL OVERHANG ANY PART OF PAD-MOUNTED TRANSFORMER.
4. FIREPROOF DOOR, FOR EXITS FROM PUBLIC ASSEMBLY, SUCH AS AUDITORIUM, 10' CLEARANCE TO TRANSFORMER SHOULD BE INCREASED TO 25', UNLESS THERE IS BARRIER.
5. MINIMUM CLEARANCES IN FRONT OF TRANSFORMER DOORS IS A MINIMUM OF 10' AND MUST BE ACCESSIBLE AT ALL TIMES.
6. MINIMUM CLEARANCES FOR WATER AND GAS METERS SHALL BE A MINIMUM OF 3'.
7. MINIMUM CLEARANCES FOR PROPANE TANKS SHALL BE A MINIMUM OF 10'.

CLEARANCES OF PAD-MOUNTED EQUIPMENT FROM SHRUBS, PLANTS AND OTHER OBSTRUCTIONS

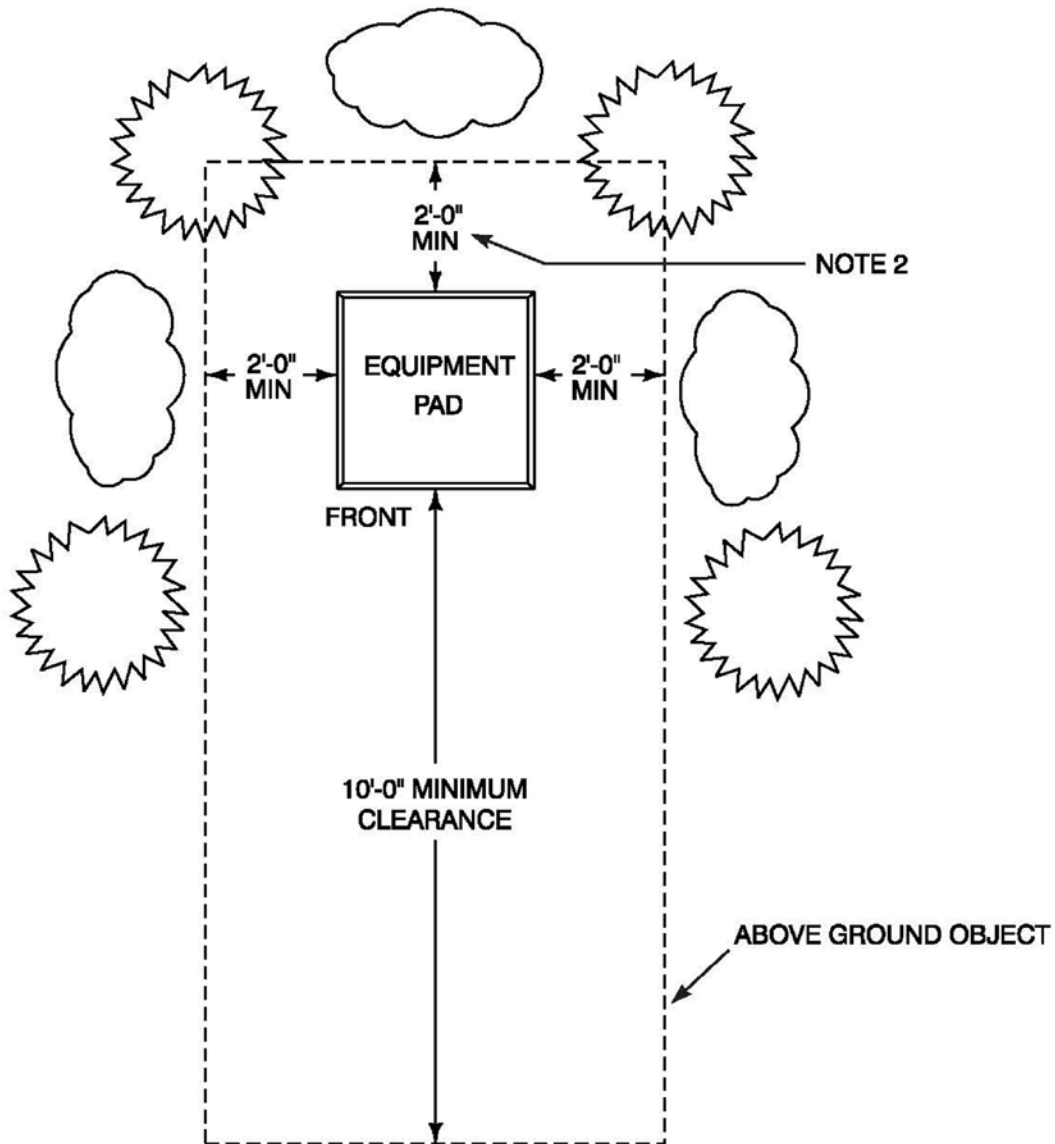

NOTES:

1. 2' MINIMUM DIMENSION IS CLEARANCE THAT SHALL BE MAINTAINED WHEN PLANTS REACH MATURITY
2. IF PAD-MOUNTED EQUIPMENT IS SWITCH OR OTHER SIMILAR DEVICE WITH FRONT AND REAR DOORS, THIS DISTANCE SHALL BE INCREASED TO 10'.
3. WARNING – PAD-MOUNTED TRANSFORMER AND PAD-MOUNTED EQUIPMENT HAVE UNDERGROUND ELECTRIC CABLES ENTERING AND EXITING THEM BELOW GRADE. WHEN IT IS DECIDED TO INSTALL PLANTS AROUND PAD, CALL PA ONE CALL - 811.

VEHICULAR BARRIER FOR PAD-MOUNTED EQUIPMENT
CONSULT COOPERATIVE FOR DETAIL BEFORE INSTALLATION

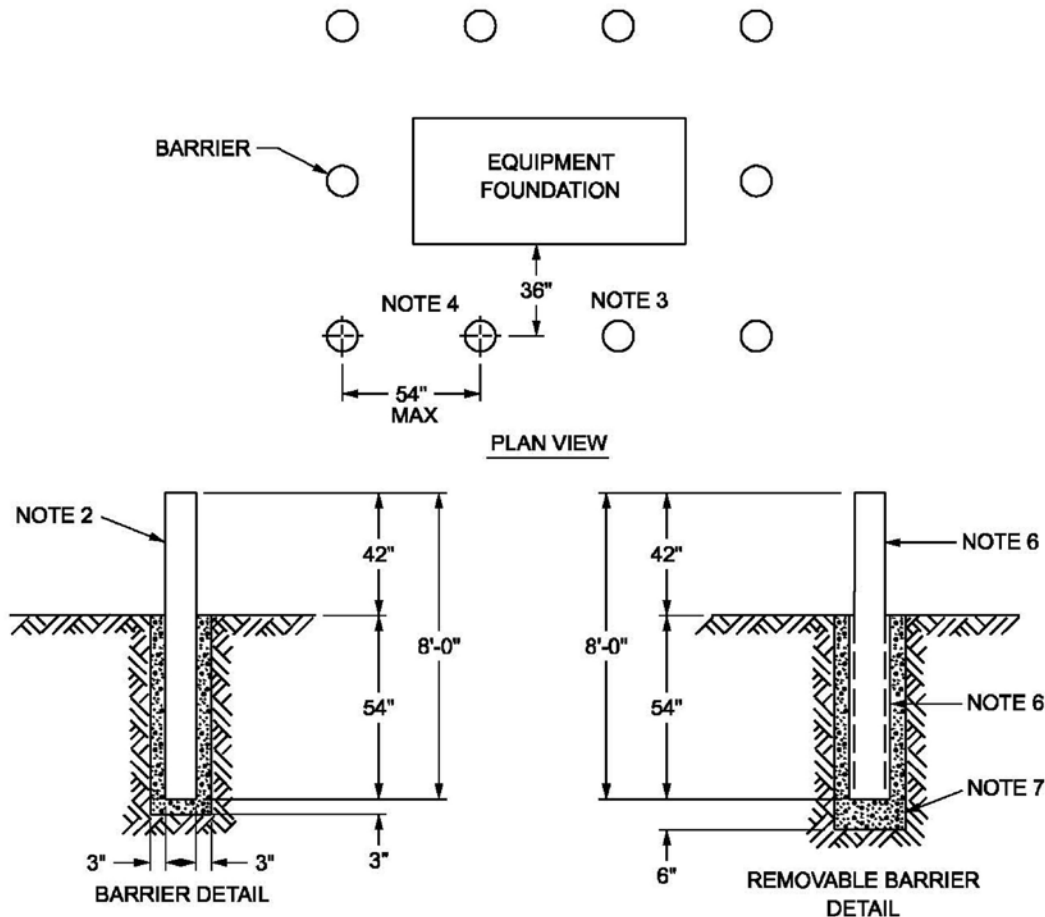

NOTES:

1. USE BARRIER TO PROTECT EQUIPMENT FROM POSSIBLE DAMAGE FROM VEHICLES.
2. USE 6" RIGID GALVANIZED STEEL CONDUIT, CUT TO 8' AND FILL WITH CONCRETE. ENCASE IN 3" OF CONCRETE, AS SHOWN.
3. THIS DISTANCE MAY BE REDUCED TO 24" PROVIDED CLEARANCES ARE MAINTAINED FOR ITEMS SUCH AS TRANSFORMER RADIATORS AND EQUIPMENT DOOR OPENINGS.
4. PROVIDE CLEARANCE FOR REMOVAL OR REPLACEMENT OF EQUIPMENT WHEN OVERHEAD OBSTACLES PREVENT REMOVAL OF EQUIPMENT, ONE BARRIER SHALL BE REMOVABLE.
5. WHEN NECESSARY, HEIGHT OF BARRIER ABOVE GROUND MAY BE INCREASED TO PREVENT LARGE VEHICLES FROM STRIKING PAD-MOUNTED EQUIPMENT
6. FOR REMOVABLE VEHICLE BARRIERS, USE 6" PVC SCHEDULE 40 CONDUIT, CUT TO 54" AND ENCASED IN CONCRETE. INSERT 8' OF 5" GALVANIZED STEEL CONDUIT, WITH CAP, INTO PVC CONDUIT.
7. USE 6" OF COMPACTED STONE OR GRAVEL FOR SUMP.
8. BARRIER PLANS MUST BE REVIEWED BY THE COOPERATIVE PRIOR TO CONSTRUCTION.

CONCRETE & NON-CONCRETE PAD FOUNDATION PAD-MOUNTED TRANSFORMER GENERAL NOTES

CONSULT COOPERATIVE FOR DETAIL BEFORE INSTALLATION

NOTES:

1. CONTACT COOPERATIVE FOR FOUNDATION REQUIREMENTS AND DETAILS PRIOR TO COMMENCEMENT OF DESIGN OR CONSTRUCTION. CONTACT COOPERATIVE FOR ALL NON-CONCRETE FOUNDATIONS – INCLUDING SINGLE PHASE PAD-MOUNTED TRANSFORMERS.
2. INSTALL ALL CONDUITS BEFORE PLACING PAD. CONDUITS SHOULD NOT BE PLACED UNDER SECTIONS OF PAD SUPPORTING TRANSFORMER SO THAT ORIGINAL GROUND WILL NOT BE DISTURBED.
3. CONDUIT SHALL BE RIGID TYPE II PVC, SCHEDULE 40, SCHEDULE 80 PVC OR GALVANIZED STEEL.
4. BACKFILL SHALL BE CLEAN GRANULAR SOIL, FREE OF LARGE STONES AND PERISHABLE MATERIAL. ALL BACKFILL SHALL BE SPREAD AND COMPACTED IN MAXIMUM LAYERS OF 8 INCHES.
5. THOROUGHLY COMPACT CRUSHED STONE OR GRAVEL.
6. CONCRETE PAD MAY BE POURED IN PLACE OR MAY BE PRECAST.
7. TO PREVENT WATER MIGRATION FROM CONCRETE WHEN POURING, PLACE WATERPROOF MEMBRANE ON CRUSHED STONE OR GRAVEL BEFORE POURING CONCRETE.
8. SEAL ALL OPENINGS AROUND CONDUITS WITH GROUT; CAP ALL SPARE CONDUITS TO PREVENT ENTRY OF RODENTS AND ANIMALS INTO TRANSFORMER COMPARTMENT.
9. IF CONDUIT EXTENDS INTO BUILDING, IT SHALL BE SEALED (PER NEC) AT BUILDING END TO PREVENT GAS FROM ENTERING BUILDING THROUGH THE CONDUIT.
10. WHERE DAMAGE TO TRANSFORMER BY VEHICLES IS POSSIBLE, TRANSFORMER SHALL BE PROTECTED BY APPROPRIATE BARRIER SHOWN ON FIGURE 26.
11. COMMUNICATION GROUND - BONDING OF ALL COMMUNICATIONS EQUIPMENT (TELEPHONE, CATV, ETC.) THAT ARE WITHIN 6' OF THE PAD IS REQUIRED. CONNECTION FOR COMMUNICATIONS GROUND SHALL BE MINIMUM #6 SOLID COPPER WIRE, THAT IS ATTACHED DIRECTLY TO THE GROUND RODS, AND EXTENDS 9" BEYOND THE EDGE OF THE CONCRETE PAD FOUNDATION.

TYPICAL TRENCHING DETAILS FOR INSTALLATION OF SECONDARY/SERVICE LATERAL AND PRIMARY CONDUIT

SECONDARY/SERVICE CONDUIT AT POLE

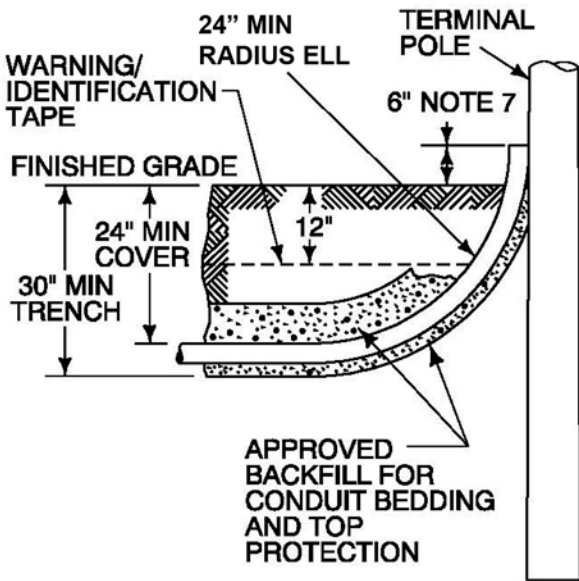

SECONDARY/SERVICE LATERAL TRENCH

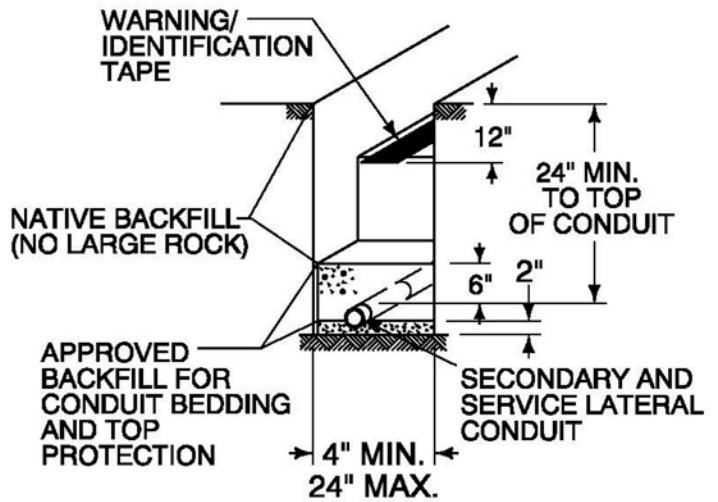

PRIMARY CONDUIT AT POLE

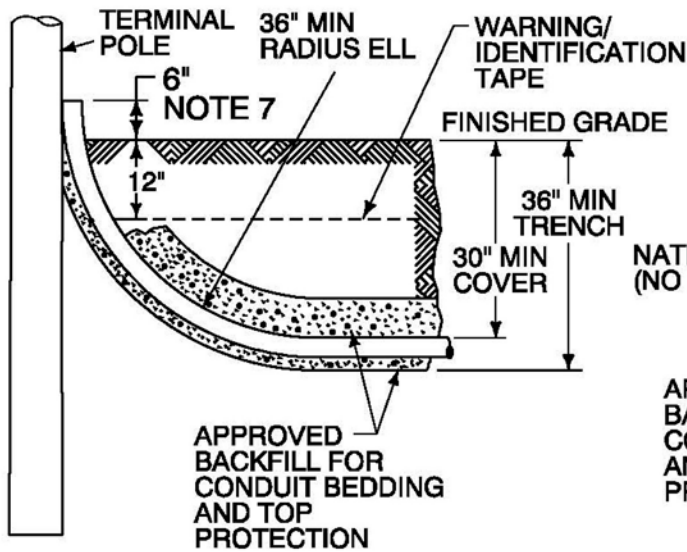

PRIMARY TRENCH

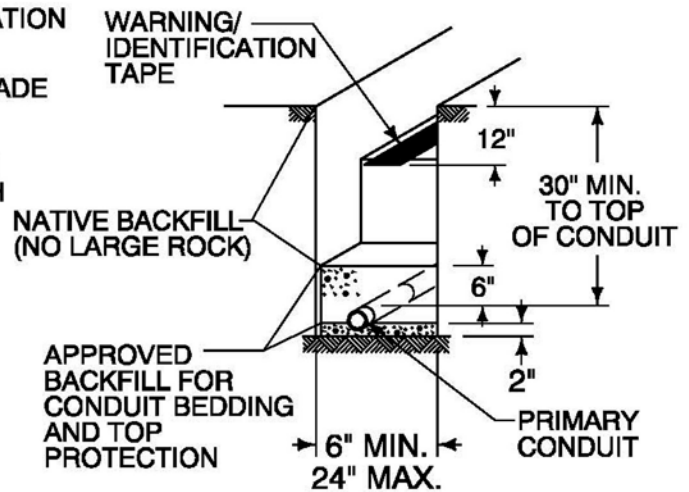

(NEXT PAGE)

TYPICAL TRENCHING DETAILS FOR INSTALLATION OF SECONDARY/SERVICE LATERAL AND PRIMARY CONDUIT GENERAL NOTES

NOTES:

1. **MEMBER** SHALL CONTACT COOPERATIVE FOR LOCATION OF COOPERATIVE FACILITY AND ROUTE OF UNDERGROUND CONDUIT. **MEMBER** SHALL TRENCH AND BACKFILL AND FURNISH AND INSTALL CONDUIT WITH APPROVED PULL ROPE FOR COOPERATIVE TO INSTALL CONDUCTORS. ANY FAILURE OF THIS PULL ROPE SHALL BE CORRECTED BY THE **MEMBER**. TRENCH SHALL BE EXCAVATED IN LOCATION INDICATED BY COOPERATIVE AND GRADED TO WITHIN 6 INCHES OF FINISHED GRADE.
2. THE BOTTOM OF TRENCH MUST BE APPROVED BACKFILL, WHICH IS FREE OF ROCK, CINDERS, OR SHARP OBJECTS. **MEMBER** SHALL BACKFILL ABOVE CONDUIT BEDDING USING APPROVED BACKFILL TO A DEPTH 12" BELOW FINISHED GRADE AND INSTALL IDENTIFICATION TAPE PROVIDED BY **MEMBER**. THE REMAINDER OF THE TRENCH SHALL BE BACKFILLED TO GRADE USING APPROVED BACKFILL MATERIAL. ALL BACKFILL LAYERS SHALL BE TAMPED AND COMPACTED TO AVOID SETTLING.
3. APPROVED BACKFILL FOR CONDUIT BEDDING AND COVER SHALL BE ROCK-FREE EARTH OR TOPSOIL WITH NO STONES LARGER THAN 1-1/2 INCH IN DIAMETER.
4. **SECONDARY AND SERVICE** LATERAL CONDUITS SHALL BE SCHEDULE 40 PVC INCLUDING SWEEP ELL (24" MINIMUM RADIUS) AT TERMINAL POLE AND TRANSFORMER. ALL CONDUITS SHALL BE ELECTRICAL GRADE. **MEMBER** SHALL CONTACT COOPERATIVE FOR PROPER SECONDARY/SERVICE CONDUIT DIAMETER.
5. **PRIMARY** CONDUITS ARE SIZED FOR INSTALLATION OF CONDUCTORS. **MEMBER** SHALL CONTACT COOPERATIVE FOR PROPER **PRIMARY** CONDUIT DIAMETER. CONDUIT TYPE SHALL BE SCHEDULE 40 SWEEP ELL (36" MINIMUM RADIUS) AT TERMINAL POLE AND TRANSFORMER. ALL CONDUITS SHALL BE ELECTRICAL GRADE. FOR BENDING RADIUSSES LESS THAN 36" **MEMBER** SHOULD CONSULT WITH COOPERATIVE FIRST.
6. PRIMARY, SECONDARY AND SERVICE LATERAL CONDUITS MAY BE INSTALLED IN THE SAME TRENCH, PROVIDED THE PRIMARY TRENCH COVER DIMENSIONS ARE USED.
7. **MEMBER** TO MAINTAIN PROPER COVER DEPTH, SWEEP ELL SHALL NOT EXTEND MORE THAN 6" ABOVE GRADE AT POLE. COOPERATIVE SHALL EXTEND CONDUIT RISER UP POLE (**RISER IS SUPPLIED BY MEMBER FOR PRIMARY AND SECONDARY CONDUIT LARGER THAN 2-1/2" ALONG WITH SIX STRAPS AND LAGS AND WEATHERHEAD**). **MEMBER TO LEAVE LAST CONDUIT JOINT AND SWEEP OFF AT RISER POLE.**
8. THE **MEMBER** SHALL COORDINATE THE JOINT USE/OCCUPANCY OF THE TRENCH WITH OTHER UTILITIES IF ALLOWED.
9. A MINIMUM OF A 12" LATERAL SEPARATION BETWEEN ELECTRIC CONDUITS AND TELEPHONE OR CATV FACILITIES IS REQUIRED BY THE COOPERATIVE. THE **MEMBER** SHALL DETERMINE THE SEPARATION REQUIRED BY THE TELEPHONE OR CATV COMPANIES, IN WHICH CASE THE POWER CABLE DEPTHS SHOWN MAY HAVE TO BE INCREASED TO MAINTAIN SEPARATION. CONSULT THE COOPERATIVE IF THE TRENCH DEPTH MUST BE MORE THAN 4 FEET.

Typical Meter Location and Installation

RESIDENTIAL SERVICE-METER LOCATION

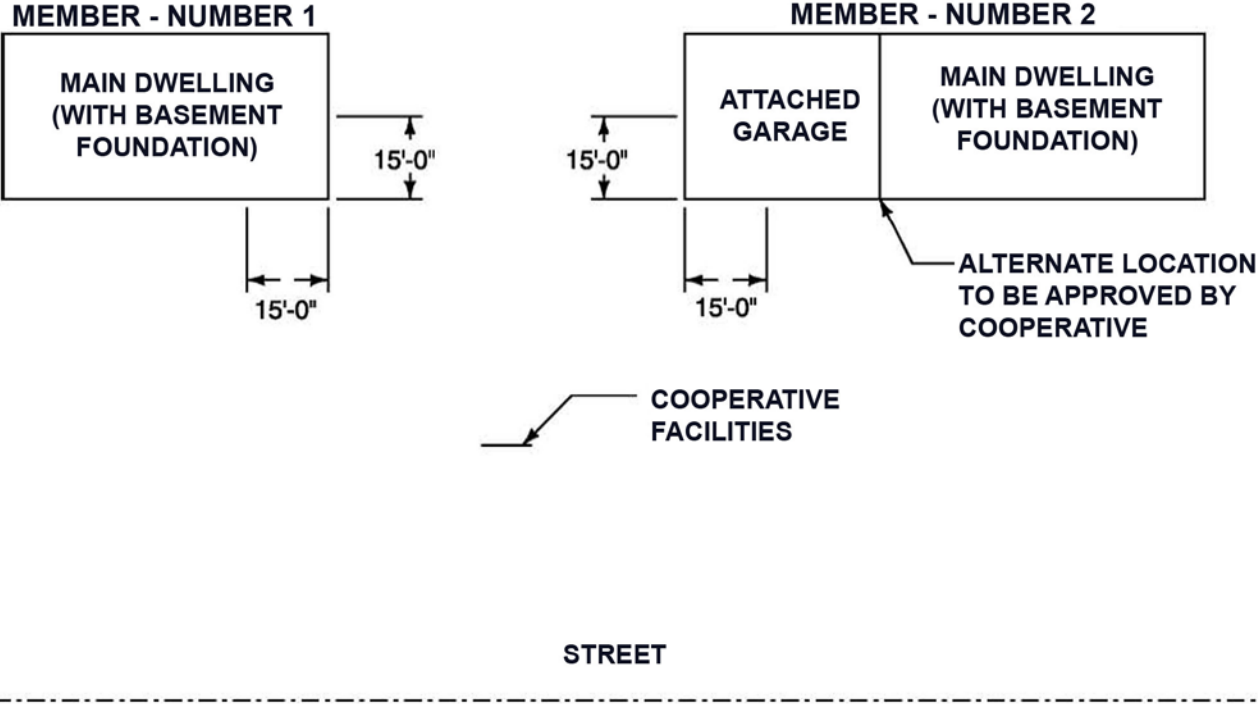

NOTES:

- 1. **MEMBER** SHALL CONTACT COOPERATIVE FOR METER LOCATION.
- 2. METER SHALL BE WITHIN 15' OF OUTSIDE CORNER CLOSEST TO COOPERATIVE'S SERVICE FACILITIES.

SELF-CONTAINED METER SOCKET CONNECTIONS

OVERHEAD ONLY



120/240 VOLT
3 WIRE
SINGLE-PHASE
100 AND 200 AMP.

UNDERGROUND ONLY

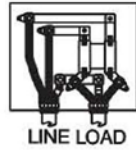

120/240 VOLT
3 WIRE
SINGLE-PHASE
200 AMP.

UNDERGROUND

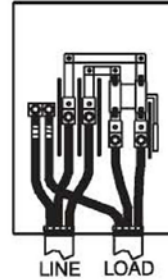

120/240 VOLT
3 WIRE
SINGLE-PHASE
320 AMP.

OVERHEAD

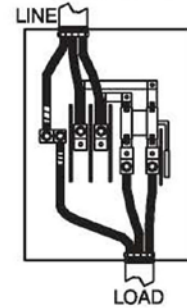

120/240 VOLT
3 WIRE
SINGLE-PHASE
320 AMP.

OVERHEAD ONLY

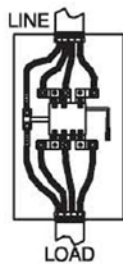

208Y/120 VOLT
240/120 VOLT*
480Y/277 VOLT
4 WIRE
THREE-PHASE
200 AMP.

* PUT HIGH LEG/PHASE OF
240/120 VOLT DELTA ON RIGHT
JAW OF METER SOCKET.

UNDERGROUND
OR OVERHEAD

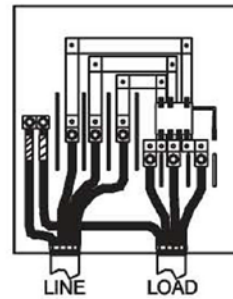

208Y/120 VOLT
240/120 VOLT*
480Y/277 VOLT
4 WIRE
THREE-PHASE
320 AMP.

NOTES:

1. ALL METER SOCKETS SHALL BE RINGLESS-TYPE AND SUITABLE FOR PLUG-IN METERS.
2. **INHIBITOR COMPOUND** SHALL BE USED ON ALL ALUMINUM WIRE TERMINATIONS.
3. ALL SELF CONTAINED 3 PHASE METER SOCKETS SHALL HAVE A BYPASS SWITCH.

MULTIPLE METER INSTALLATIONS 240 VOLTS OR LESS

CONSULT COOPERATIVE FOR DETAIL BEFORE INSTALLATION

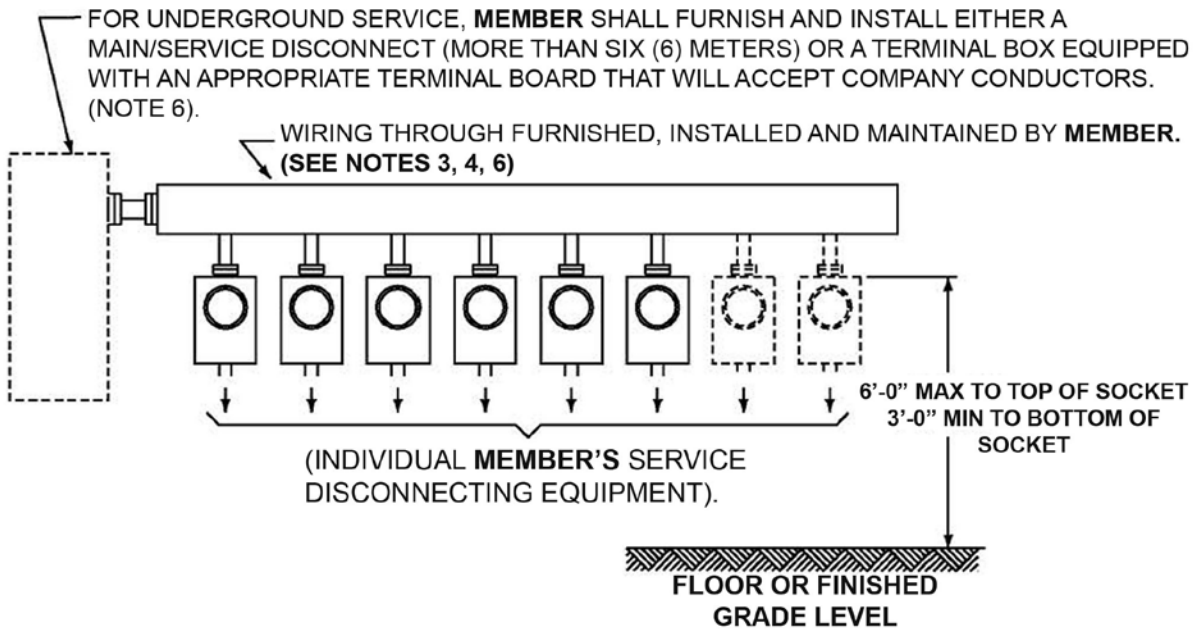

NOTES:

1. **MEMBER SHALL CONSULT WITH COOPERATIVE** FOR POINT OF ATTACHMENT OF SERVICE LATERAL OR DROP, METERING LOCATION, AND PROPOSED SERVICE ENTRANCE FACILITIES PRIOR TO PROCEEDING WITH THIS INSTALLATION.
2. ALL **MEMBER** WORK SHALL BE COMPLETED AND INSPECTIONS OBTAINED (SEE SECTION 4.06) BEFORE COOPERATIVE WILL PROVIDE SERVICE.
3. **MEMBER** SHALL BE RESPONSIBLE FOR FURNISHING, INSTALLING AND CONNECTING ALL SERVICE ENTRANCE WIRING FROM TERMINAL BOX OR MAIN DISCONNECT TO METER SOCKETS AND ALSO BE RESPONSIBLE FOR ENSURING THAT TERMINAL BOX OR MAIN DISCONNECT HAS PROPER NUMBER, SIZE AND TYPE TERMINALS TO ACCEPT COOPERATIVE SERVICE LATERAL. **MEMBER** TO SUPPLY SERVICE LATERAL FOR WIRE SIZE LARGER THAN 4/0 ALUMINUM.
4. **MEMBER** SHALL FURNISH AND INSTALL ALL METER SOCKETS AND CONNECT ALL CONDUCTORS IN METER SOCKETS. **MEMBER** SHALL PERMANENTLY AND **CLEARLY LABEL EACH METER SOCKET** TO SHOW AREA SERVED.
5. COOPERATIVE WILL FURNISH AND INSTALL METERS.
6. **METERED CONDUCTORS SHALL NOT BE INSTALLED IN WIRING TROUGH(S).**
7. **MEMBER** MAY INSTALL METER STACK OR METER TROUGH TYPE EQUIPMENT SUBJECT TO COOPERATIVE APPROVAL.
8. WHEN SERVICE ENTRANCE CONSISTS OF MORE THAN ONE SET OF CONDUCTORS, INDIVIDUAL LOADS SHALL BE CONNECTED SO AS TO BE BALANCED AMONG ALL SETS OF CONDUCTORS.
9. WIRING TROUGH(S), MAIN SERVICE DISCONNECT OR TERMINAL BOX SHALL BE SEALABLE AND SHALL ALSO BE WEATHERPROOF WHEN INSTALLED OUTDOORS.

10. **INHIBITOR COMPOUND** SHALL BE USED ON ALL ALUMINUM WIRE TERMINALS.

PRE-ASSEMBLED MULTIPLE METER INSTALLATION

CONSULT COOPERATIVE FOR DETAIL BEFORE INSTALLATION

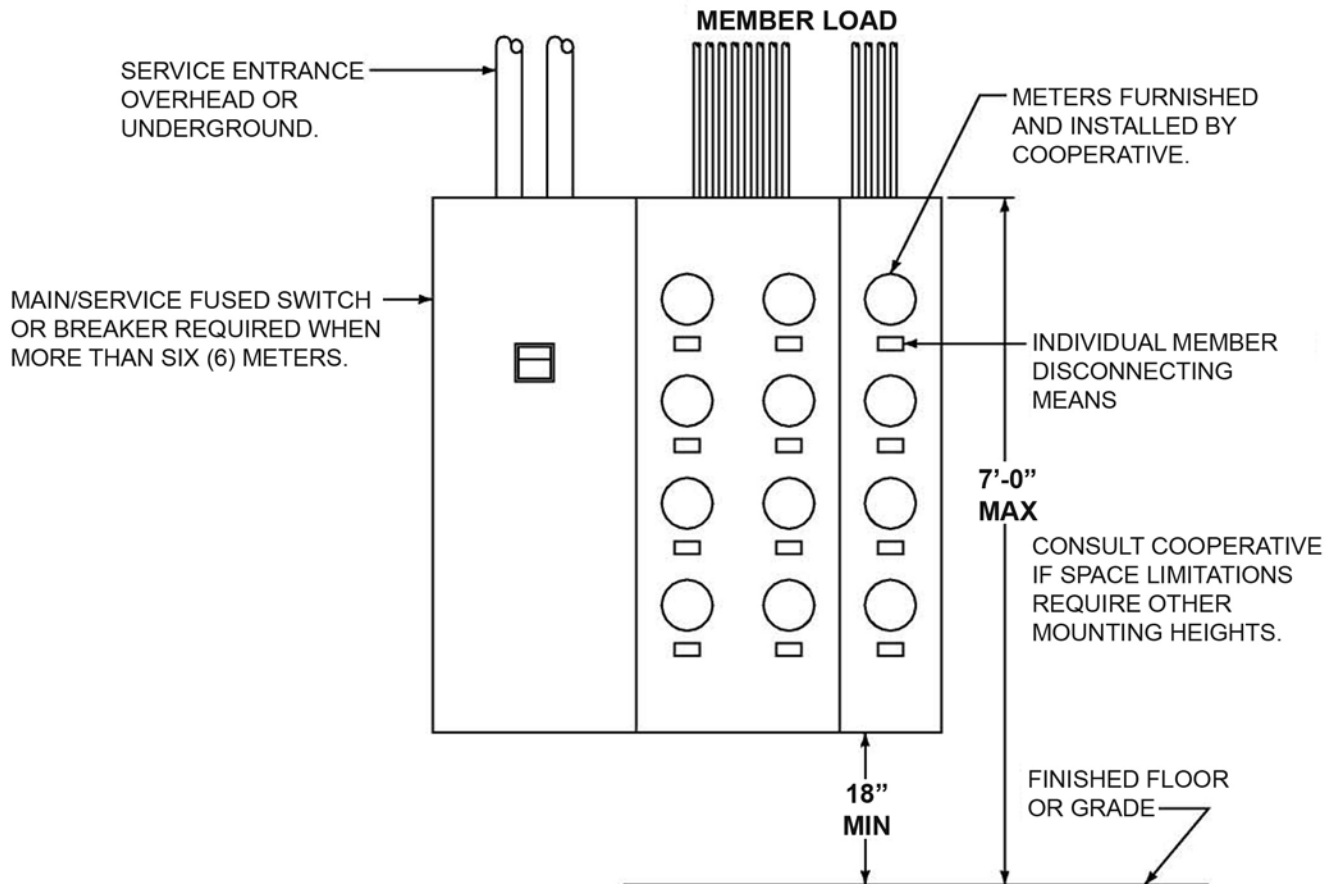

NOTES:

1. **MEMBER SHALL CONSULT WITH COOPERATIVE** FOR POINT OF ATTACHMENT OF SERVICE LATERAL OR DROP, METERING LOCATION, AND PROPOSED SERVICE ENTRANCE FACILITIES PRIOR TO PROCEEDING WITH THIS INSTALLATION.
2. ALL **MEMBER** WORK SHALL BE COMPLETED AND INSPECTIONS OBTAINED (SEE SECTION 4.06) BEFORE COOPERATIVE WILL PROVIDE SERVICE.
3. **MEMBER** SHALL FURNISH, INSTALL AND CONNECT SEALABLE MULTIPLE METERING EQUIPMENT FOR OVERHEAD SERVICE. **MEMBER** SHALL FURNISH AND CONNECT SERVICE ENTRANCE CONDUCTORS. FOR UNDERGROUND SERVICE, COOPERATIVE WILL EXTEND ITS UNDERGROUND CONDUCTORS TO MAIN LUGS IN **MEMBER** METER STACK AND MAKE CONNECTIONS.
4. **MEMBER** SHALL PERMANENTLY AND **CLEARLY LABEL EACH METER SOCKET** TO SHOW AREAS SERVED.
5. **INHIBITOR COMPOUND** SHALL BE USED ON ALL ALUMINUM WIRE TERMINALS.

TYPICAL TRANSFORMER-RATED METERING INSTALLATION 600 VOLTS OR LESS – OUTDOOR OVERHEAD

CONSULT COOPERATIVE FOR DETAIL BEFORE INSTALLATION

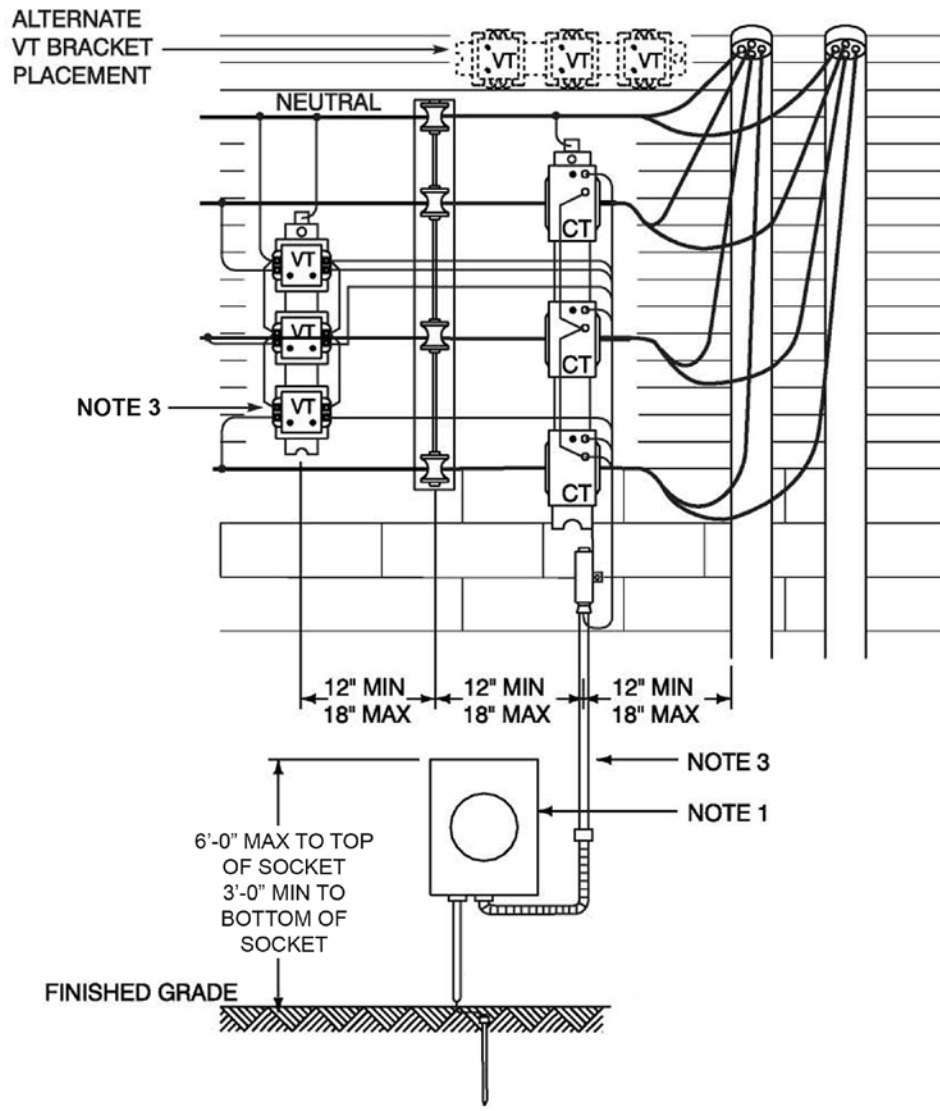

NOTES:

1. METERING TRANSFORMER PACKAGE AND METER SOCKET FURNISHED AND INSTALLED BY COOPERATIVE.
2. SEE FIGURE 1 FOR CLEARANCES.
3. VOLTAGE TRANSFORMERS REQUIRED FOR 480Y/277 VOLT SERVICE AND ARE TYPICALLY MOUNTED ON OPPOSITE SIDE OF SERVICE DROP POINT OF ATTACHMENT FROM CURRENT TRANSFORMERS.

Fax Cover Sheet, Worksheets

FAX COVER SHEET

Date: _____

To: REA Energy Cooperative, Inc. Indiana, PA

Fax: 724-349-7151

From: _____ Fax Number: _____
(include area code)

Location: _____

Number of pages to follow: _____

If you do not receive pages properly, please contact: _____
(Phone number with area code & contact)

To: _____

(PLEASE TYPE OR PRINT THE INFORMATION USING BLACK INK)

WORKSHEET FOR NEW RESIDENTIAL ELECTRIC SERVICE

(This sheet to follow FAX Cover Sheet)

MEMBER or COMPANY Name: _____

MEMBER Mailing Address: _____

(If MEMBER Name) Date of Birth: _____ Social Security #: _____

(If COMPANY Name) Tax ID # or EIN #: _____

Phone Number: (____) _____ FAX Number: (____) _____

Contractor Name: _____ Contractor Phone #: _____

Subdivision Name & Lot No.: _____ County: _____

New Home Address: _____
(Street Address, City, State, Zip Code)

Type of Dwelling: _____ Temporary Construction Power Needed: Yes No

Service entrance size: 100 amp 200 amp 400 amp Other _____

Service entrance type: Overhead Underground (Charges may apply)

Stage of Construction: staked foundation in framing under roof

Square Footage of Dwelling (**REQUIRED**): _____

Electric Heat: Yes No (If yes, indicate type below - if no, go to other heating types)

Baseboard _____ kW

Electric Furnace _____ kW

Heat Pump _____ ton unit and _____ kW auxiliary _____ Amps Starting (Locked Rotor)

Geothermal Heat Pump _____ ton unit _____ kW auxiliary _____ Amps Starting (Locked Rotor)

Other Heating Types: Natural Gas Bottled Gas Oil Coal Other: _____

Furnace Boiler Baseboard

Please mark if any of the following apply:

Electric water heater Electric air conditioning: _____ ton unit or size in BTU's

Heat Pump _____ ton unit or size in BTU's Electric Oven Electric Dryer

Other Electric Appliance Over 2 kW

Detailed directions to new home site: _____

WORKSHEET FOR UPGRADE RESIDENTIAL SERVICE

MEMBER Name: _____

Address: _____

Account #: _____ Meter # (**REQUIRED**): _____

MEMBER Phone #: () _____ Work Phone #: () _____

Contact Person for Scheduling _____ Phone #: () _____

Fax #: () _____

Directions: _____

Existing Service Size: 60 Amp 100 Amp 200 Amp

Upgrading To: 100 Amp 200 Amp 400 Amp Other (**Explain**): _____

Are you moving the location of meter socket? Yes No

Are you changing the point of attachment of overhead line to your house? Yes No

(COOPERATIVE shall approve meter socket location and point of attachment. COOPERATIVE may require a move in meter socket location or point of attachment change as a result of upgrade)

Are you switching from overhead to underground service? Yes No

Please check all applicable equipment upgrades or changes:

Entire Service – (**no need to check other individual boxes**)

Entrance cable or service mast Meter socket Panel box Main disconnect Grounding

Proposed completion date? (**Local Service Center will schedule appointments**) _____
(ASAP not accepted)

ADDITIONAL INFORMATION

If adding electric heat? Furnace _____ kW Heat Pump _____ kW _____ Tons _____ Amps Starting (LRA)

Baseboard _____ kW

If adding air conditioning? _____ Tons _____ Amps Starting (LRA – Locked Rotor Amps)

Additional information (include all electrical appliances and the respective kW rating): _____

WORKSHEET FOR NEW NON-RESIDENTIAL ELECTRIC SERVICE

MEMBER (Party to be billed)	Member/Company Name: _____ DBA: _____ EIN/SS#: _____ DOB: _____ Telephone: _____ Billing Address: _____ City: _____ State: _____ Zip Code: _____ E-mail: _____																																																												
JOB ADDRESS	Service Address: _____ City: _____ State: _____ Zip Code: _____ County: _____ Township: _____ Development: _____ Lot #: _____																																																												
SERVICE TO:	Building/site use: _____ Square Footage: _____ Operating Hours/Day: _____ /Week: _____																																																												
CONTACT DETAILS	Contact Name: _____ Telephone #: _____ Cell #: _____ Alt #: _____ Fax #: _____ E-mail: _____																																																												
ELECTRIC SERVICE DETAILS	Temporary Service Required? _____ Service Entrance Size (Amps): _____ Overhead: <input type="checkbox"/> Underground: <input type="checkbox"/> 1 or 3 Phase: _____ Voltage: _____ / _____ Permanent Service - Service Entrance Size (Amps): _____ Overhead: <input type="checkbox"/> Underground: <input type="checkbox"/> 1 or 3 Phase: _____ Voltage: _____ / _____																																																												
LOAD	<p style="text-align: center;">Note: Failure to complete load information may cause service delay.</p> <table border="1" style="width: 100%; border-collapse: collapse;"> <thead> <tr> <th style="width: 60%;">Description</th> <th style="width: 10%;">1PH</th> <th style="width: 10%;">Hours/Day</th> <th style="width: 10%;">3PH</th> <th style="width: 10%;">Hours/Day</th> </tr> </thead> <tbody> <tr><td>Air Conditioning – kW</td><td></td><td></td><td></td><td></td></tr> <tr><td>Space Heating - kW</td><td></td><td></td><td></td><td></td></tr> <tr><td>Water Heating – kW</td><td></td><td></td><td></td><td></td></tr> <tr><td>Refrigeration - kW</td><td></td><td></td><td></td><td></td></tr> <tr><td>Cooking - kW</td><td></td><td></td><td></td><td></td></tr> <tr><td>Process Heating - kW</td><td></td><td></td><td></td><td></td></tr> <tr><td>Lighting - kW</td><td></td><td></td><td></td><td></td></tr> <tr><td>Misc. – kW</td><td></td><td></td><td></td><td></td></tr> <tr><td>Motors – total connected kW *</td><td></td><td></td><td></td><td></td></tr> <tr><td>Largest Motor - HP</td><td></td><td></td><td></td><td></td></tr> <tr><td>Electronic Equip - kW</td><td></td><td></td><td></td><td></td></tr> </tbody> </table> <p style="margin-left: 20px;">1. Attach all other load information on separate sheet. 2. Provide a list for all 1 and 3 phase motors. (see page 58)</p>	Description	1PH	Hours/Day	3PH	Hours/Day	Air Conditioning – kW					Space Heating - kW					Water Heating – kW					Refrigeration - kW					Cooking - kW					Process Heating - kW					Lighting - kW					Misc. – kW					Motors – total connected kW *					Largest Motor - HP					Electronic Equip - kW				
Description	1PH	Hours/Day	3PH	Hours/Day																																																									
Air Conditioning – kW																																																													
Space Heating - kW																																																													
Water Heating – kW																																																													
Refrigeration - kW																																																													
Cooking - kW																																																													
Process Heating - kW																																																													
Lighting - kW																																																													
Misc. – kW																																																													
Motors – total connected kW *																																																													
Largest Motor - HP																																																													
Electronic Equip - kW																																																													
COMMENTS	Stage of Construction: _____ Closest Pole or Pad-mounted Transformer #: _____ Directions: _____ _____ Submitted by (Required): _____																																																												
REA USE ONLY	Work Order # _____																																																												

WORKSHEET FOR UPGRADE NON-RESIDENTIAL SERVICE

Account # _____ Meter # _____

Contact Person: _____

Contact Phone Number: _____

MEMBER Name: _____

MEMBER E-mail: _____

Project Name/Job Location: _____

ELECTRIC SERVICE DETAILS	<p>Permanent Service</p> <p>Existing Service Entrance Size (Amps): _____ Overhead: <input type="checkbox"/> Underground: <input type="checkbox"/></p> <p>New Service Entrance Size (Amps): _____ Overhead: <input type="checkbox"/> Underground: <input type="checkbox"/></p> <p>1 or 3 Phase: ___ Voltage: ____/____</p>																																																																																				
LOAD	<p>Note: Failure to complete load information may cause service delay.</p> <table border="1" style="width: 100%; border-collapse: collapse;"> <thead> <tr> <th style="width: 45%;">Description</th> <th style="width: 10%;">Existing 1PH</th> <th style="width: 10%;">New 1PH</th> <th style="width: 10%;">Hours/Day</th> <th style="width: 10%;">Existing 3PH</th> <th style="width: 10%;">New 3PH</th> <th style="width: 10%;">Hours/Day</th> </tr> </thead> <tbody> <tr><td>Air Conditioning – kW</td><td></td><td></td><td></td><td></td><td></td><td></td></tr> <tr><td>Space Heating - kW</td><td></td><td></td><td></td><td></td><td></td><td></td></tr> <tr><td>Water Heating – kW</td><td></td><td></td><td></td><td></td><td></td><td></td></tr> <tr><td>Refrigeration - kW</td><td></td><td></td><td></td><td></td><td></td><td></td></tr> <tr><td>Cooking - kW</td><td></td><td></td><td></td><td></td><td></td><td></td></tr> <tr><td>Process Heating - kW</td><td></td><td></td><td></td><td></td><td></td><td></td></tr> <tr><td>Lighting - kW</td><td></td><td></td><td></td><td></td><td></td><td></td></tr> <tr><td>Misc. – kW</td><td></td><td></td><td></td><td></td><td></td><td></td></tr> <tr><td>Motors - total connected kW *</td><td></td><td></td><td></td><td></td><td></td><td></td></tr> <tr><td>Largest Motor - HP</td><td></td><td></td><td></td><td></td><td></td><td></td></tr> <tr><td>Sensitive Electronic Equip – kW</td><td></td><td></td><td></td><td></td><td></td><td></td></tr> </tbody> </table> <p>1. Attach all other load information on separate sheet. 2. Provide a list for all 1 and 3 phase motors. (see page 58)</p>	Description	Existing 1PH	New 1PH	Hours/Day	Existing 3PH	New 3PH	Hours/Day	Air Conditioning – kW							Space Heating - kW							Water Heating – kW							Refrigeration - kW							Cooking - kW							Process Heating - kW							Lighting - kW							Misc. – kW							Motors - total connected kW *							Largest Motor - HP							Sensitive Electronic Equip – kW						
Description	Existing 1PH	New 1PH	Hours/Day	Existing 3PH	New 3PH	Hours/Day																																																																															
Air Conditioning – kW																																																																																					
Space Heating - kW																																																																																					
Water Heating – kW																																																																																					
Refrigeration - kW																																																																																					
Cooking - kW																																																																																					
Process Heating - kW																																																																																					
Lighting - kW																																																																																					
Misc. – kW																																																																																					
Motors - total connected kW *																																																																																					
Largest Motor - HP																																																																																					
Sensitive Electronic Equip – kW																																																																																					
COMMENTS	<p>Additional Notes or Directions: _____</p> <p>_____</p> <p>_____</p> <p>Submitted by (Required): _____</p>																																																																																				
REA USE ONLY	<p>Work Order # _____</p>																																																																																				

MOTOR SPECIFICATIONS WORKSHEET

Please provide the following information for all motors. (List motors starting with the largest.)

	Motor 1	Motor 2	Motor 3	Motor 4	Motor 5
Description / Purpose / Use					
Horsepower Rating in HP					
Voltage & No. of Phases	___ V_∅	___ V_∅	___ V_∅	___ V_∅	___ V_∅
Service Factor					
RPM at full load					
Locked-Rotor kVA Code (letter)					
LRA (Locked Rotor Amps) (If marked)					
Indicate Either No. of Starts per Hour or Starts per Day	___/Hr ___/Day	___/Hr ___/Day	___/Hr ___/Day	___/Hr ___/Day	___/Hr ___/Day
Design Letter (A, B, C or D)					
FLA (Full Load Amps)					
Efficiency (If marked)					
Power Factor (If marked)					
Reduce Voltage Start Y / N? Provide the Method of Starting	Y / N	Y / N	Y / N	Y / N	Y / N

The Typical Methods of Starting are Across the Line, Wye-Delta Starting, Resistor Starting, Reactor Starting, Autotransformer Starting, Solid State Starting, or Adjustable Speed Drive Starting.

	Motor 6	Motor 7	Motor 8	Motor 9	Motor 10
Description / Purpose / Use					
Horsepower Rating in HP					
Voltage & No. of Phases	___ V_∅	___ V_∅	___ V_∅	___ V_∅	___ V_∅
Service Factor					
RPM at full load					
Locked-Rotor kVA Code (letter)					
LRA (Locked Rotor Amps) (If marked)					
Indicate Either No. of Starts per Hour or Starts per Day	___/Hr ___/Day	___/Hr ___/Day	___/Hr ___/Day	___/Hr ___/Day	___/Hr ___/Day
Design Letter (A, B, C or D)					
FLA (Full Load Amps)					
Efficiency (If marked)					
Power Factor (If marked)					
Reduce Voltage Start Y / N? Provide the Method of Starting	Y / N	Y / N	Y / N	Y / N	Y / N

The Typical Methods of Starting are Across the Line, Wye-Delta Starting, Resistor Starting, Reactor Starting, Autotransformer Starting, Solid State Starting, or Adjustable Speed Drive Starting.

Total motor load for motors not shown above: _____